



PRODUCT SPECIFICATION

规格书

Customer (客户名称):
Customer P/N (客户料号):
Aillen P/N(爱伦料号):
CATEGORY(品名):
DESCRIPTION(型号):
Spec No.(承认书编号):
Date(发行日期):

AILLEN	
PREPARED (拟定)	CHECKED (审核)

CUSTOMER	
Please sign a copy after accepting	
APPROVAL (批准)	SIGNATURE (签名)

香港九龙尖沙咀柯士甸路 7-9 号焕利商业大厦 7 楼 63 室

Room 63,7/F,Woon Lee Commercial Building,7-9 Austin Ave, Tsim Sha Tsui, Kowloon, Hong Kong

广东省东莞市沙田镇进港中路 28 号

ADD:No. 28, Jingang Middle Road, Shatian Town, Dongguan City, Guangdong Province

TEL: 0769 86059566 <http://www.aillen.com>

1. Application

This specification applies to polar Aluminum electrolytic capacitor (foil type) used in electronic equipment.

Designed capacitor's quality meets IEC60384.

2. Part Number System

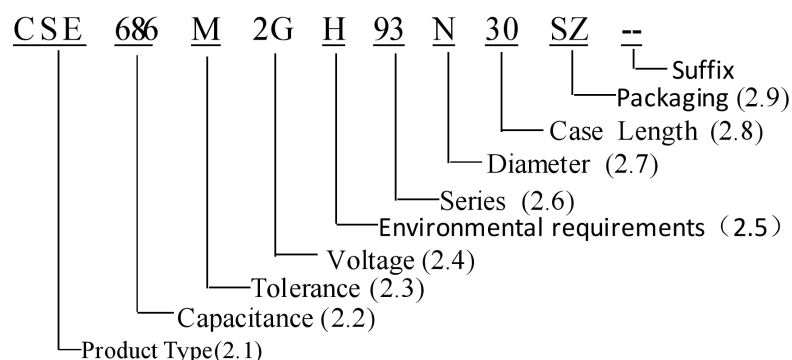

2.1 Product Type:

Code	CSE
Product Type	Snap-in

2.2 Capacitance code

Code	337	338	339
Capacitance (μF)	330	3300	33000

2.3 Capacitance tolerance

Code	M	V
Tolerance Range	±20%	-10%~+20%

2.4 Rated voltage code

Code	0J	1A	1C	1E	1V	1H	1J	1K	2A
Voltage (W.V.)	6.3	10	16	25	35	50	63	80	100
Code	2C	2E	2V	2G	2W	2H			
Voltage (W.V.)	160	250	350	400	450	500			

2.5 Environmental requirements

Code	R	H
Environmental requirements	ROHS Requirements	ROHS Requirements and Halogen Free

2.6 Products Series Code:

Code	CDDP
Series	DP

2.7 Diameter

Code	M	N	O	P	Q
Diameter	20	22	25	30	35

2.8 Case length

(1) When the code is number, it represent the actual height.(e.g. The code 20 indicates that the height is 20mm; The code 35 indicates that the height is 35mm)

(2) When the code is number + alphabet, please check the following the table:

Code	1A	1B	1C	1D	2A	3A
Case Length(mm)	11.5	12.5	13.5	14.5	21.5	31.5

2.9 Packaging:

Code	SW	SZ
Packaging	W-Type	Z- Type

2.10 Suffix: Inner Code

3. Construction

Single ended type to be produced to fix the terminals to anode and cathode foil, and wind together with paper, and then wound element to be impregnated with electrolyte will be enclosed in an aluminum case. Finally sealed up tightly with end seal rubber, then finished by putting on the vinyl sleeve.

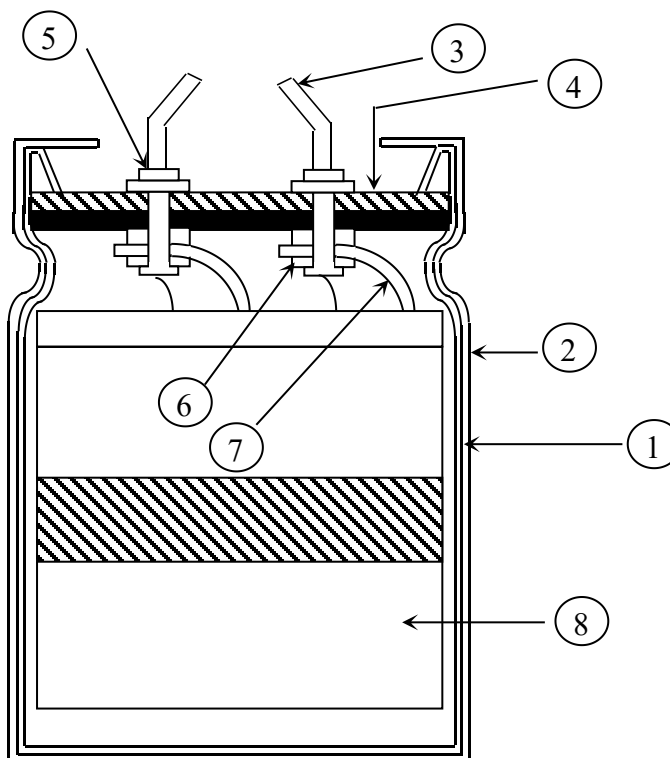

No	Component	Material
1	Case	Aluminum case
2	Sleeve	PET
3	Terminal	Solder coated copper clad steel
4	Seal	Rubber-laminated bake lite
5	Rivet	Aluminum
6	Washer	Aluminum
7	Tab	Aluminum
8	Element	Aluminum foil & Electrolyte paper

4. Characteristics

Standard atmospheric conditions
 Unless otherwise specified, the standard range of atmospheric conditions for making measurements and tests is as follows:

Ambient temperature	: 15°C to 35°C
Relative humidity	: 45% to 85%
Air Pressure	: 86kPa to 106kPa

If there is any doubt about the results, measurement shall be made within the following conditions:

Ambient temperature	: 20°C ± 2°C
Relative humidity	: 60% to 70%
Air Pressure	: 86kPa to 106kPa

Operating temperature range
 The ambient temperature range at which the capacitor can be operated continuously at rated voltage is (160WV to 250WV) -40°C to 85°C or (385WV to 450WV) -25°C to 85°C.

As to the detailed information, please refer to table 1

Table 1

Item		Performance																
4.1	Nominal capacitance (Tolerance)	<p><Condition> Measuring Frequency : 120Hz±12Hz Measuring Voltage : Not more than 0.5V Measuring Temperature : 20±2℃</p> <p><Criteria> Shall be within the specified capacitance tolerance.</p>																
4.2	Leakage current	<p><Condition> Connecting the capacitor with a protective resistor (1kΩ ± 10Ω) in series for 5 minutes, and then, measure leakage current.</p> <p><Criteria> $I \leq 3\sqrt{CV}$ (μA)</p> <p>I: Leakage current (μA) C: Capacitance (μF) V: Rated DC working voltage (V)</p>																
4.3	tan δ	<p><Condition> See 4.1 Nominal capacitance, for measuring frequency, voltage and temperature.</p> <p><Criteria></p> <table border="1"> <tr> <td>Working voltage (v)</td> <td>160</td> <td>200</td> <td>250</td> <td>350</td> <td>385</td> <td>400</td> <td>450</td> </tr> <tr> <td>tan δ (Max.)</td> <td>0.15</td> <td>0.15</td> <td>0.15</td> <td>0.15</td> <td>0.15</td> <td>0.15</td> <td>0.20</td> </tr> </table>	Working voltage (v)	160	200	250	350	385	400	450	tan δ (Max.)	0.15	0.15	0.15	0.15	0.15	0.15	0.20
Working voltage (v)	160	200	250	350	385	400	450											
tan δ (Max.)	0.15	0.15	0.15	0.15	0.15	0.15	0.20											
4.4	Rated voltage (WV) Surge voltage (SV)	<table border="1"> <tr> <td>WV (V.DC)</td> <td>160</td> <td>180</td> <td>200</td> <td>250</td> <td>350</td> <td>400</td> <td>450</td> </tr> <tr> <td>SV (V.DC)</td> <td>200</td> <td>220</td> <td>250</td> <td>300</td> <td>400</td> <td>450</td> <td>500</td> </tr> </table>	WV (V.DC)	160	180	200	250	350	400	450	SV (V.DC)	200	220	250	300	400	450	500
WV (V.DC)	160	180	200	250	350	400	450											
SV (V.DC)	200	220	250	300	400	450	500											

4.5	Terminal strength	<p><Condition></p> <p>A static load of 25N (2.5kgf) shall be applied to the lead wire terminal in the axial direction away from the capacitor body for 30s.</p> <p><Criteria></p> <p>There shall be no intermittent contacts, open or short circuit and there shall be no mechanical damage such as terminal damage.</p>
-----	-------------------	--

4.6	Temperature characteristics	<p><Condition></p> <table border="1" style="margin-left: auto; margin-right: auto;"> <thead> <tr> <th>STEP</th> <th>Testing Temperature(°C)</th> <th>Time</th> </tr> </thead> <tbody> <tr> <td style="text-align: center;">1</td> <td style="text-align: center;">20±2</td> <td>Time to reach thermal equilibrium</td> </tr> <tr> <td style="text-align: center;">2</td> <td style="text-align: center;">-40±3/-25±3</td> <td>Time to reach thermal equilibrium</td> </tr> <tr> <td style="text-align: center;">3</td> <td style="text-align: center;">20±2</td> <td>Time to reach thermal equilibrium</td> </tr> <tr> <td style="text-align: center;">4</td> <td style="text-align: center;">85±2</td> <td>Time to reach thermal equilibrium</td> </tr> <tr> <td style="text-align: center;">5</td> <td style="text-align: center;">20±2</td> <td>Time to reach thermal equilibrium</td> </tr> </tbody> </table> <p><Criteria></p> <p>a. At +85°C, capacitance measured shall be within ±20% of its original value at +20°C. tanδ shall be within the limit of Item 4.3 The leakage current measured shall not more than 8 times of its specified value.</p> <p>b. In step 5, tanδ shall be within the limit of Item 4.3 The leakage current shall not more than the specified value.</p> <p>c. At -40°C/-25°C, Impedance (Z) ratio shall not exceed the value of the following table.</p> <table border="1" style="margin-left: auto; margin-right: auto;"> <thead> <tr> <th>Rated Voltage (V)</th> <th>160~250</th> <th>385</th> <th>400~450</th> </tr> </thead> <tbody> <tr> <td>Z-25°C/ Z +20°C</td> <td style="text-align: center;">5</td> <td style="text-align: center;">8</td> <td style="text-align: center;">8</td> </tr> <tr> <td>Z-40°C/ Z +20°C</td> <td style="text-align: center;">/</td> <td style="text-align: center;">/</td> <td style="text-align: center;">/</td> </tr> </tbody> </table> <p>Capacitance, tan δ , and impedance shall be measured at 120Hz.</p>	STEP	Testing Temperature(°C)	Time	1	20±2	Time to reach thermal equilibrium	2	-40±3/-25±3	Time to reach thermal equilibrium	3	20±2	Time to reach thermal equilibrium	4	85±2	Time to reach thermal equilibrium	5	20±2	Time to reach thermal equilibrium	Rated Voltage (V)	160~250	385	400~450	Z-25°C/ Z +20°C	5	8	8	Z-40°C/ Z +20°C	/	/	/
STEP	Testing Temperature(°C)	Time																														
1	20±2	Time to reach thermal equilibrium																														
2	-40±3/-25±3	Time to reach thermal equilibrium																														
3	20±2	Time to reach thermal equilibrium																														
4	85±2	Time to reach thermal equilibrium																														
5	20±2	Time to reach thermal equilibrium																														
Rated Voltage (V)	160~250	385	400~450																													
Z-25°C/ Z +20°C	5	8	8																													
Z-40°C/ Z +20°C	/	/	/																													

4.7	Load life test	<p><Condition></p> <p>According to IEC60384-4No.4.13 methods, The capacitor is stored at a temperature of 85±2°C with DC bias voltage plus the rated ripple current for 5000+48/0 hours. (The sum of DC and ripple peak voltage shall not exceed the rated working voltage) Then the product should be tested after 16 hours recovering time at atmospheric conditions. The result should meet the following table:</p> <p><Criteria></p> <p>The characteristic shall meet the following requirements.</p> <table border="1" style="margin-left: auto; margin-right: auto;"> <tr> <td>Leakage current</td> <td>Value in 4.2 shall be satisfied</td> </tr> <tr> <td>Capacitance Change</td> <td>Within ±20% of initial value.</td> </tr> <tr> <td>tanδ</td> <td>Not more than 200%of the specified value.</td> </tr> <tr> <td>Appearance</td> <td>There shall be no leakage of electrolyte.</td> </tr> </table>	Leakage current	Value in 4.2 shall be satisfied	Capacitance Change	Within ±20% of initial value.	tanδ	Not more than 200%of the specified value.	Appearance	There shall be no leakage of electrolyte.
Leakage current	Value in 4.2 shall be satisfied									
Capacitance Change	Within ±20% of initial value.									
tanδ	Not more than 200%of the specified value.									
Appearance	There shall be no leakage of electrolyte.									

4.8	Shelf life test	<p><Condition></p> <p>The capacitors are then stored with no voltage applied at a temperature of 85±2°C for 1000H+48/0 hours. Following this period the capacitors shall be removed from the test chamber and be allowed to stabilized at room temperature for 4~8 hours. Next they shall be connected to a series limiting resistor(1k±100Ω) with D.C. rated voltage applied for 30min. After which the capacitors shall be discharged, and then, tested the characteristics.</p> <p><Criteria></p> <p>The characteristic shall meet the following requirements.</p> <table border="1" style="margin-left: auto; margin-right: auto;"> <tr> <td>Leakage current</td> <td>Value in 4.2 shall be satisfied</td> </tr> <tr> <td>Capacitance Change</td> <td>Within ±15% of initial value.</td> </tr> <tr> <td>tanδ</td> <td>Not more than 150%of the specified value.</td> </tr> <tr> <td>Appearance</td> <td>There shall be no leakage of electrolyte.</td> </tr> </table> <p>Remark: If the capacitors are stored more than 1 year, the leakage current may increase. Please apply voltage through about 1kΩ resistor, if necessary.</p>	Leakage current	Value in 4.2 shall be satisfied	Capacitance Change	Within ±15% of initial value.	tanδ	Not more than 150%of the specified value.	Appearance	There shall be no leakage of electrolyte.
Leakage current	Value in 4.2 shall be satisfied									
Capacitance Change	Within ±15% of initial value.									
tanδ	Not more than 150%of the specified value.									
Appearance	There shall be no leakage of electrolyte.									

4.9	Surge test	<p><Condition></p> <p>Applied a surge voltage to the capacitor connected with a $(100 \pm 50)/C_R$ (k Ω) resistor. The capacitor shall be submitted to 1000 cycles, each consisting of charge of $30 \pm 5s$, followed discharge of 5 min 30s. The test temperature shall be 15~35°C. C_R :Nominal Capacitance (μF)</p> <p><Criteria></p> <table border="1"> <tr> <td>Leakage current</td> <td>Not more than the specified value.</td> </tr> <tr> <td>Capacitance Change</td> <td>Within $\pm 15\%$ of initial value.</td> </tr> <tr> <td>tan δ</td> <td>Not more than the specified value.</td> </tr> <tr> <td>Appearance</td> <td>There shall be no leakage of electrolyte.</td> </tr> </table> <p>Attention: This test simulates over voltage at abnormal situation only. It is not applicable to such over voltage as often applied.</p>	Leakage current	Not more than the specified value.	Capacitance Change	Within $\pm 15\%$ of initial value.	tan δ	Not more than the specified value.	Appearance	There shall be no leakage of electrolyte.
Leakage current	Not more than the specified value.									
Capacitance Change	Within $\pm 15\%$ of initial value.									
tan δ	Not more than the specified value.									
Appearance	There shall be no leakage of electrolyte.									

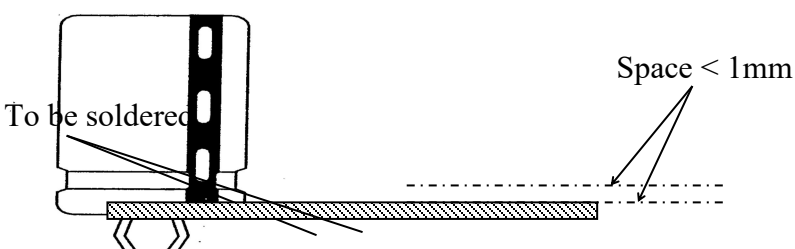
4.10	Vibration test	<p><Condition></p> <p>The following conditions shall be applied for 2 hours in each 3 mutually perpendicular directions. Vibration frequency range : 10Hz ~ 55Hz Peak to peak amplitude : 1.5mm Sweep rate : 10Hz ~ 55Hz ~ 10Hz in about 1 minute</p> <p><Criteria></p> <p>After the test, the following items shall be tested:</p> <table border="1"> <tr> <td>Inner construction</td> <td>No intermittent contact, open or short circuit. No damage of tab terminals or electrodes.</td> </tr> <tr> <td>Appearance</td> <td>No mechanical damage in terminal. No leakage of electrolyte or swelling of the case. The markings shall be legible.</td> </tr> </table> <p>Mounting method: The capacitor must be fixed in place with a bracket.</p> 	Inner construction	No intermittent contact, open or short circuit. No damage of tab terminals or electrodes.	Appearance	No mechanical damage in terminal. No leakage of electrolyte or swelling of the case. The markings shall be legible.
Inner construction	No intermittent contact, open or short circuit. No damage of tab terminals or electrodes.					
Appearance	No mechanical damage in terminal. No leakage of electrolyte or swelling of the case. The markings shall be legible.					

4.11	Solderability test	<p><Condition> The capacitor shall be tested under the following conditions: Soldering temperature : 245±3°C Dipping depth : 2mm Dipping speed : 25±2.5mm/s Dipping time : 3±0.5s</p> <p><Criteria></p> <table border="1" data-bbox="550 607 1406 689"> <tr> <td>Coating quality</td> <td>A minimum of 95% of the surface being immersed</td> </tr> </table>	Coating quality	A minimum of 95% of the surface being immersed																
Coating quality	A minimum of 95% of the surface being immersed																			
4.12	Resistance to solder heat test	<p><Condition> Terminals of the capacitor shall be immersed into solder bath at 260±5°C for 10±1 seconds or 400±10°C for 3⁺¹₋₀ seconds to 1.5~2.0mm from the body of capacitor.</p> <p>Then the capacitor shall be left under the normal temperature and normal humidity for 1~2 hours before measurement.</p> <p><Criteria></p> <table border="1" data-bbox="550 992 1410 1173"> <tr> <td>Leakage current</td> <td>Not more than the specified value.</td> </tr> <tr> <td>Capacitance Change</td> <td>Within ±10% of initial value.</td> </tr> <tr> <td>tanδ</td> <td>Not more than the specified value.</td> </tr> <tr> <td>Appearance</td> <td>There shall be no leakage of electrolyte.</td> </tr> </table>	Leakage current	Not more than the specified value.	Capacitance Change	Within ±10% of initial value.	tanδ	Not more than the specified value.	Appearance	There shall be no leakage of electrolyte.										
Leakage current	Not more than the specified value.																			
Capacitance Change	Within ±10% of initial value.																			
tanδ	Not more than the specified value.																			
Appearance	There shall be no leakage of electrolyte.																			
4.13	Change of temperature test	<p><Condition> Temperature cycle: According to IEC60384-4 No.4.7 methods, capacitor shall be placed in an oven, the condition according as below:</p> <table border="1" data-bbox="550 1335 1390 1552"> <thead> <tr> <th>Temperature</th> <th>Time</th> </tr> </thead> <tbody> <tr> <td>(1)+20°C</td> <td>≤3 Minutes</td> </tr> <tr> <td>(2) -25°C(-40°C)</td> <td>30±2 Minutes</td> </tr> <tr> <td>(3) +85°C</td> <td>30±2 Minutes</td> </tr> <tr> <td colspan="2">(1) to (3)=1 cycle, total 5 cycle</td> </tr> </tbody> </table> <p><Criteria> The characteristic shall meet the following requirement.</p> <table border="1" data-bbox="550 1653 1410 1823"> <tr> <td>Capacitance Change</td> <td>Within ±10% of initial value.</td> </tr> <tr> <td>Leakage current</td> <td>Not more than the specified value.</td> </tr> <tr> <td>tanδ</td> <td>Not more than the specified value.</td> </tr> <tr> <td>Appearance</td> <td>There shall be no leakage of electrolyte.</td> </tr> </table>	Temperature	Time	(1)+20°C	≤3 Minutes	(2) -25°C(-40°C)	30±2 Minutes	(3) +85°C	30±2 Minutes	(1) to (3)=1 cycle, total 5 cycle		Capacitance Change	Within ±10% of initial value.	Leakage current	Not more than the specified value.	tanδ	Not more than the specified value.	Appearance	There shall be no leakage of electrolyte.
Temperature	Time																			
(1)+20°C	≤3 Minutes																			
(2) -25°C(-40°C)	30±2 Minutes																			
(3) +85°C	30±2 Minutes																			
(1) to (3)=1 cycle, total 5 cycle																				
Capacitance Change	Within ±10% of initial value.																			
Leakage current	Not more than the specified value.																			
tanδ	Not more than the specified value.																			
Appearance	There shall be no leakage of electrolyte.																			

4.14	Damp heat test	<p><Condition> Humidity test: According to IEC60384-4 No.4.12 methods, capacitor shall be exposed for 500±8 hours in an atmosphere of 90~95%R H .at 40±2°C, the characteristic change shall meet the following requirement.</p> <p><Criteria></p> <table border="1" data-bbox="539 600 1353 779"> <tr> <td>Leakage current</td> <td>Not more than the specified value.</td> </tr> <tr> <td>Capacitance Change</td> <td>Within ±20% of initial value.</td> </tr> <tr> <td>tanδ</td> <td>Not more than 120% of the specified value.</td> </tr> <tr> <td>Appearance</td> <td>There shall be no leakage of electrolyte.</td> </tr> </table>	Leakage current	Not more than the specified value.	Capacitance Change	Within ±20% of initial value.	tanδ	Not more than 120% of the specified value.	Appearance	There shall be no leakage of electrolyte.												
Leakage current	Not more than the specified value.																					
Capacitance Change	Within ±20% of initial value.																					
tanδ	Not more than 120% of the specified value.																					
Appearance	There shall be no leakage of electrolyte.																					
4.15	Vent test	<p><Condition> The following test only apply to those products with vent. D.C. test The capacitor is connected with its polarity reversed to a DC power source. Then a current selected from Table 2 is applied.</p> <p><Table 2></p> <table border="1" data-bbox="564 1025 1066 1111"> <thead> <tr> <th>Diameter (mm)</th> <th>DC Current (A)</th> </tr> </thead> <tbody> <tr> <td>22.4 or less</td> <td>10</td> </tr> </tbody> </table> <p><Criteria> The vent shall operate with no dangerous conditions such as flames or dispersion of pieces of the capacitor and/or case.</p>	Diameter (mm)	DC Current (A)	22.4 or less	10																
Diameter (mm)	DC Current (A)																					
22.4 or less	10																					
4.16	Maximum permissible (ripple current, temperature coefficient)	<p><Condition> The maximum permissible ripple current is the maximum A.C current at 120Hz and can be applied at maximum operating temperature</p> <p>Table-3 The combined value of D.C voltage and the peak A.C voltage shall not exceed the rated voltage and shall not reverse voltage.</p> <p>Frequency multipliers:</p> <table border="1" data-bbox="545 1527 1305 1751"> <thead> <tr> <th rowspan="2">Coefficient \ Freq. (Hz)</th> <th>60</th> <th>120</th> <th>1k</th> <th>10~50k</th> </tr> </thead> <tbody> <tr> <th>Voltage (V)</th> <td></td> <td></td> <td></td> <td></td> </tr> <tr> <td>160~250V</td> <td>0.80</td> <td>1.00</td> <td>1.15</td> <td>1.47</td> </tr> <tr> <td>385~500V</td> <td>0.80</td> <td>1.00</td> <td>1.15</td> <td>1.47</td> </tr> </tbody> </table>	Coefficient \ Freq. (Hz)	60	120	1k	10~50k	Voltage (V)					160~250V	0.80	1.00	1.15	1.47	385~500V	0.80	1.00	1.15	1.47
Coefficient \ Freq. (Hz)	60	120		1k	10~50k																	
	Voltage (V)																					
160~250V	0.80	1.00	1.15	1.47																		
385~500V	0.80	1.00	1.15	1.47																		

5. Product printing diagram and terminal size diagram:

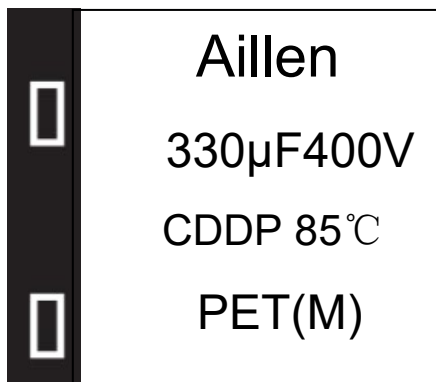

SW

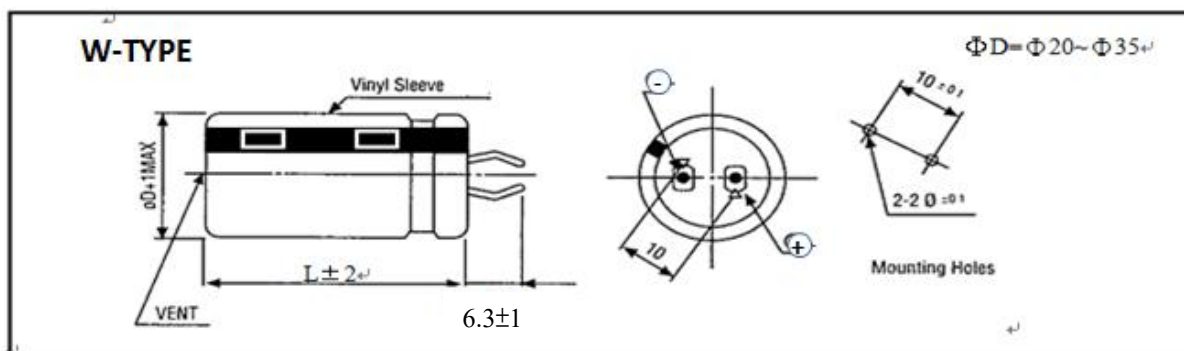

SZ

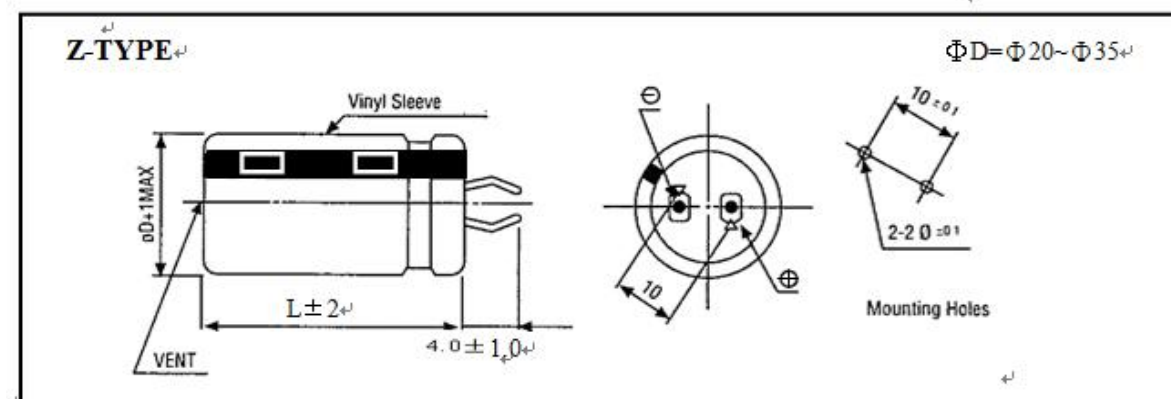

Table-3 CASE SIZE & MAX RIPPLE CURRENT

Size $\phi D \times L$ (mm) , Maximum Permissible Ripple Current (Arms) at 85°C 120Hz
Maximum Impedance (m Ω) at 20°C 20kHz

Voltage		160V(2C)			200V(2D)			250V(2E)		
Cap. (μF)	Code	Case Size	Impedance (m Ω)	Ripple Current	Case Size	Impedance (m Ω)	Ripple Current	Case Size	Impedance (m Ω)	Ripple Current
150	157							22x25	800	0.91
220	227	22x25	730	1.10	22x25	490	1.10	22x30	500	1.20
								25x25	490	1.20
330	337	22x30	490	1.40	22x30	330	1.40	22x40	330	1.60
					25x25	330	1.50	25x30	330	1.60
470	477	22x35	350	1.80	22x40	240	1.90	25x40	240	2.10
					30x25	350	1.90	30x30	240	2.00
680	687	25x35	240	2.40	25x40	160	2.50	30x40	160	2.70
					30x30	160	2.40			
1000	108	30x35	160	3.10	30x40	120	3.30	35x40	120	3.60
					35x35	120	3.50			
1500	158	30x45	120	4.20	35x45	80	4.60			
2200	228	35x50	80	5.80						

Size $\phi D \times L$ (mm) , Maximum Permissible Ripple Current at 85°C 120Hz
Maximum Impedance (m Ω) at 20°C 20kHz

Voltage		385V(2Y)			400V(2G)		
Cap.(μF)	Code	Case Size	Impedance (m Ω)	Ripple Current	Case Size	Impedance (m Ω)	Ripple Current
68	686	22x25	1570	0.61			
100	107	22x30	1070	0.79	22x30	1070	0.79
		25x25	1070	0.80	25x25	1070	0.80
120	127				22x35	890	0.92
150	157	22x40	720	1.10	22x40	720	1.10
		25x30	720	1.00	30x25	720	1.10
180	187				30x30	600	1.20
220	227	25x40	490	1.40	25x40	490	1.40
		30x30	490	1.40	30x35	490	1.50
270	277				30x35	400	1.60
330	337	30x40	330	1.90	30x45	330	2.00
390	397				30x50	280	2.20
470	477	35x40	240	2.50	35x45	240	2.60
560	567	35x45	200	2.80	35x50	200	2.90

Issued-date: 2026-03-20

Name

Specification Sheet – CDDP

Revision

B

Page

13

STANDARD MANUAL

Size $\phi D \times L$ (mm) , Maximum Permissible Ripple Current (Arms) at 85°C 120Hz
Maximum Impedance (m Ω) at 20°C 20kHz

Voltage		420V(2M)			450V(2W)		
Cap.(μ F)	Code	Case Size	Impedance (m Ω)	Ripple Current	Case Size	Impedance (m Ω)	Ripple Current
47	476				22x25	3400	0.51
68	686				22x30	2350	0.65
					25x25	2350	0.66
100	107	22x30	1600	0.79	22x40	1600	0.88
		25x25	1600	0.80	25x30	1600	0.86
					30x25	1600	0.90
150	157	22x40	1070	1.08	25x40	1070	1.20
		25x35	1070	1.11	30x30	1070	1.10
180	187	25x35	890	1.21	30x35	890	1.30
		30x30	890	1.26			
220	227	25x40	730	1.41	30x40	730	1.50
		30x35	730	1.46			
270	277	30x35	590	1.62	30x45	600	1.80
		35x30	590	1.71			
330	337	30x45	490	1.96	35x40	490	2.10
		35x35	490	1.98			
470	477	35x45	340	2.58	35x50	350	2.70
560	567	35x50	290	2.93			

Remark:

The sizes in the above table are all general specifications. If you need other specifications, please contact us.

Attachment: Application Guidelines

1. Circuit Design

1.1 Operating Temperature and Frequency

Electrolytic capacitor electrical parameters are normally specified at 20°C temperature and 120Hz frequency. These parameters vary with changes in temperature and frequency. Circuit designers should take these changes into consideration.

(1) Effects of operating temperature on electrical parameters

- a) At higher temperatures, leakage current and capacitance increase while equivalent series resistance (ESR) decreases.
- b) At lower temperatures, leakage current and capacitance decrease while equivalent series resistance (ESR) increases.

(2) Effects of frequency on electrical parameters

- a) At higher frequencies capacitance and impedance decrease while $\tan\delta$ increases.
- b) At lower frequencies, ripple current generated heat will rise due to an increase in equivalent series resistance (ESR).

1.2 Operating Temperature and Life Expectancy

See the file: Life calculation of aluminum electrolytic capacitor

1.3 Common Application Conditions to Avoid

The following misapplication load conditions will cause rapid deterioration to capacitor electrical parameters. In addition, rapid heating and gas generation within the capacitor can occur causing the pressure relief vent to operate and resultant leakage of electrolyte. Under Leaking electrolyte is combustible and electrically conductive.

(1) Reverse Voltage

DC capacitors have polarity. Verify correct polarity before insertion. For circuits with changing or uncertain polarity, use DC bipolar capacitors. DC bipolar capacitors are not suitable for use in AC circuits.

(2) Charge / Discharge Applications

Standard capacitors are not suitable for use in repeating charge / discharge applications. For charge / discharge applications consult us and advise actual conditions.

(3) Over voltage

Do not apply voltages exceeding the maximum specified rated voltage. Voltages up to the surge voltage rating are acceptable for short periods of time. Ensure that the sum of the DC voltage and the superimposed AC ripple voltage does not exceed the rated voltage.

(4) Ripple Current

Do not apply ripple currents exceeding the maximum specified value. For high ripple current applications, use a capacitor designed for high ripple currents or contact us with your requirements.

Ensure that allowable ripple currents superimposed on low DC bias voltages do not cause reverse voltage conditions.

Issued-date: 2026-03-20

Name

Specification Sheet – CDDP

Revision

B

Page

15

STANDARD MANUAL

1.4 Using Two or More Capacitors in Series or Parallel

(1) Capacitors Connected in Parallel

The circuit resistance can closely approximate the series resistance of the capacitor causing an imbalance of ripple current loads within the capacitors. Careful design of wiring methods can minimize the possibility of excessive ripple currents applied to a capacitor.

(2) Capacitors Connected in Series

Normal DC leakage current differences among capacitors can cause voltage imbalances. The use of voltage divider shunt resistors with consideration to leakage current can prevent capacitor voltage imbalances.

1.5 Capacitor Mounting Considerations

(1) Double Sided Circuit Boards

Avoid wiring pattern runs, which pass between the mounted capacitor and the circuit board.

When dipping into a solder bath, excess solder may collect under the capacitor by capillary action and short circuit the anode and cathode terminals.

(2) Circuit Board Hole Positioning

The vinyl sleeve of the capacitor can be damaged if solder passes through a lead hole for subsequently processed parts. Special care when locating hole positions in proximity to capacitors is recommended.

(3) Circuit Board Hole Spacing

The circuit board holes spacing should match the capacitor lead wire spacing within the specified tolerances. Incorrect spacing can cause excessive lead wire stress during the insertion process. This may result in premature capacitor failure due to short or open circuit, increased leakage current, or electrolyte leakage.

(4) Clearance for Case Mounted Pressure Relief vents

Capacitors with case mounted pressure relief vents require sufficient clearance to allow for proper vent operation. The minimum clearances are dependent on capacitor diameters as proper vent operation. The minimum clearances are dependent on capacitor diameters as follows.

$\phi 6.3\sim\phi 16\text{mm}$:2mm minimum, $\phi 18\sim\phi 35\text{mm}$:3mm minimum, $\phi 40\text{mm}$ or greater:5mm minimum.

(5) Clearance for Seal Mounted Pressure Relief Vents

A hole in the circuit board directly under the seal vent location is required to allow proper release of pressure.

(6) Wiring Near the Pressure Relief Vent

Avoid locating high voltage or high current wiring or circuit board paths above the pressure relief vent.

Flammable, high temperature gas exceeding 100°C may be released which could dissolve the wire insulation and ignite.

(7) Circuit Board patterns Under the Capacitor

Avoid circuit board runs under the capacitor as electrolyte leakage could cause an electrical short.

(8) Screw Terminal Capacitor Mounting

Do not orient the capacitor with the screw terminal side of the capacitor facing downwards.

Tighten the terminal and mounting bracket screws within the torque range specified in the specification.

1.6 Electrical Isolation of the Capacitor

Completely isolate the capacitor as follows.

- (1) Between the cathode and the case (except for axially leaded B types) and between the anode terminal and other circuit paths
- (3) Between the extra mounting terminals (on T types) and the anode terminal, cathode terminal, and other circuit paths.

1.7 The Product characteristic should take the sample as the standard.

1.8 If conduct the load or shelf life test, must be collect date code within 6 months products of sampling.

1.9 Capacitor Sleeve

The vinyl sleeve or laminate coating is intended for marking and identification purposes and is not meant to electrically insulate the capacitor.

The sleeve may split or crack if immersed into solvents such as toluene or xylene, and then exposed to high temperatures.

CAUTION!

Always consider safety when designing equipment and circuits. Plan for worst case failure modes such as short circuits and open circuits which could occur during use.

- (1) Provide protection circuits and protection devices to allow safe failure modes.
- (2) Design redundant or secondary circuits where possible to assure continued operation in case of main circuit failure.

2. Capacitor Handling Techniques

2.1 Considerations Before Using

- (1) Capacitors have a finite life. Do not reuse or recycle capacitors from used equipment.
- (2) Transient recovery voltage may be generated in the capacitor due to dielectric absorption. If required, this voltage can be discharged with a resistor with a value of about 1k Ω .
- (3) Capacitors stored for long periods of time may exhibit an increase in leakage current. This can be corrected by gradually applying rated voltage in series with a resistor of approximately 1k Ω .
- (4) If capacitors are dropped, they can be damaged mechanically or electrically. Avoid using dropped capacitors.
- (5) Dented or crushed capacitors should not be used. The seal integrity can be compromised and loss of electrolyte / shortened life can result.

2.2 Capacitor Insertion

- (1) Verify the correct capacitance and rated voltage of the capacitor.
- (2) Verify the correct polarity of the capacitor before inserting.
- (3) Verify the correct hole spacing before insertion (land pattern size on chip type) to avoid stress on the terminals.
- (4) Ensure that the auto insertion equipment lead clinching operation does not stress the capacitor leads where they enter the seal of the capacitor.
For chip type capacitors, excessive mounting pressure can cause high leakage current, short circuit, or disconnection.

2.3 Manual Soldering

- (1) Observe temperature and time soldering specifications or do not exceed temperatures of 400 °C for 3 seconds or less.
- (2) If lead wires must be formed to meet terminal board hole spacing, avoid stress on the lead wire where it enters the capacitor seal.
- (3) If a soldered capacitor must be removed and reinserted, avoid excessive stress to the capacitor leads.
- (4) Avoid touching the tip of the soldering iron to the capacitor, to prevent melting of the vinyl sleeve.

2.4 Flow Soldering

- (1) Do not immerse the capacitor body into the solder bath as excessive internal pressure could result.
- (2) Observe proper soldering conditions (temperature, time, etc.) Do not exceed the specified limits.
- (3) Do not allow other parts or components to touch the capacitor during soldering.

2.5 Other Soldering Considerations

Rapid temperature rises during the preheat operation and resin bonding operation can cause cracking of the capacitor vinyl sleeve.

For heat curing, do not exceed 150°C for a maximum time of 2 minutes.

2.6 Capacitor Handling after Solder

- (1) Avoid movement of the capacitor after soldering to prevent excessive stress on the lead wires where they enter the seal.
- (2) Do not use capacitor as a handle when moving the circuit board assembly.
- (3) Avoid striking the capacitor after assembly to prevent failure due to excessive shock.

Issued-date: 2026-03-20

Name

Specification Sheet – CDDP

Revision

B

Page

18

STANDARD MANUAL

2.7 Circuit Board Cleaning

(1) Circuit boards can be immersed or ultrasonically cleaned using suitable cleaning solvents for up to 5 minutes and up to 60°C maximum temperatures. The boards should be thoroughly rinsed and dried. The use of ozone depleting cleaning agents is not recommended in the interest of protecting the environment.

(2) Avoid using the following solvent groups unless specifically allowed for in the specification;

Halogenated cleaning solvents: except for solvent resistant capacitor types, halogenated solvents can permeate the seal and cause internal capacitor corrosion and failure. For solvent resistant capacitors, carefully follow the temperature and time requirements of the specification. 1-1-1 trichloroethane should never be used on any aluminum electrolytic capacitor.

Alkali solvents : could attack and dissolve the aluminum case.

Petroleum based solvents: deterioration of the rubber seal could result.

Xylene : deterioration of the rubber seal could result.

Acetone : removal of the ink markings on the vinyl sleeve could result.

(3) A thorough drying after cleaning is required to remove residual cleaning solvents which may be trapped between the capacitor and the circuit board. Avoid drying temperatures, which exceed the maximum rated temperature of the capacitor.

(4) Monitor the contamination levels of the cleaning solvents during use by electrical conductivity, pH, specific gravity, or water content. Chlorine levels can rise with contamination and adversely affect the performance of the capacitor.
Please consult us for additional information about acceptable cleaning solvents or cleaning methods.

2.8 Mounting Adhesives and Coating Agents

When using mounting adhesives or coating agents to control humidity, avoid using materials containing halogenated solvents. Also, avoid the use of chloroprene based polymers.

After applying adhesives or coatings, dry thoroughly to prevent residual solvents from being trapped between the capacitor and the circuit board.

3. Precautions for using capacitors

3.1 Environmental Conditions

Capacitors should not be stored or used in the following environments.

(1) Temperature exposure above the maximum rated or below the minimum rated temperature of the capacitor.

(2) Direct contact with water, salt water, or oil.

(3) High humidity conditions where water could condense on the capacitor.

(4) Exposure to toxic gases such as hydrogen sulfide, sulfuric acid, nitric acid chlorine, or ammonia.

(5) Exposure to ozone, radiation, or ultraviolet rays.

(6) Vibration and shock conditions exceeding specified requirements.

3.2 Electrical Precautions

- (1) Avoid touching the terminals of the capacitor as possible electric shock could result. The exposed aluminum case is not insulated and could also cause electric shock if touched.
- (2) Avoid short circuit the area between the capacitor terminals with conductive materials including liquids such as acids or alkaline solutions.

4. Emergency Procedures

- (1) If the pressure relief vent of the capacitor operates, immediately turn off the equipment and disconnect from the power source. This will minimize additional damage caused by the vaporizing electrolyte.
- (2) Avoid contact with the escaping electrolyte gas which can exceed 100°C temperatures.
 If electrolyte or gas enters the eye, immediately flush the eyes with large amounts of water.
 If electrolyte or gas is ingested by mouth, gargle with water.
 If electrolyte contacts the skin, wash with soap and water.

5. Long Term Storage

Leakage current of a capacitor increases with long storage times. The aluminum oxide film deteriorates as a function of temperature and time. If used without reconditioning, an abnormally high current will be required to restore the oxide film. This current surge could cause the circuit or the capacitor to fail.
 After one year, a capacitor should be reconditioned by applying rated voltage in series with a 1000Ω, current limiting resistor for a time period of 30 minutes .
 If the expired date of products date code is over eighteen months, the products should be return to confirmation.

5.1 Environmental Conditions

The capacitor shall be not use in the following condition:

- (1) Temperature exposure above the maximum rated or below the minimum rated temperature of the capacitor.
- (2) Direct contact with water, salt water, or oil.
- (3) High humidity conditions where water could condense on the capacitor.
- (4) Exposure to toxic gases such as hydrogen sulfide, sulfuric acid, nitric acid, chlorine, or ammonia.
- (5) Exposure to ozone, radiation, or ultraviolet rays.
- (6) Vibration and shock conditions exceeding specified requirements.

6. Capacitor Disposal

When disposing of capacitors, use one of the following methods.
 Incinerate after crushing the capacitor or puncturing the can wall (to prevent explosion due to internal pressure rise). Capacitors should be incinerated at high temperatures to prevent the release of toxic gases such as chlorine from the polyvinyl chloride sleeve, etc.

Dispose of as solid waste.
 NOTE: Local laws may have specific disposal requirements, which must be followed.