

1. Applicable Scope:

This standard specification is for use in consumer electronics, computers, telecommunications, control instruments...etc.

2. Part Number System:

It is composed by Type, Rated Wattage, Nominal Resistance, Tolerance and Package/Terminal Form. e.g.

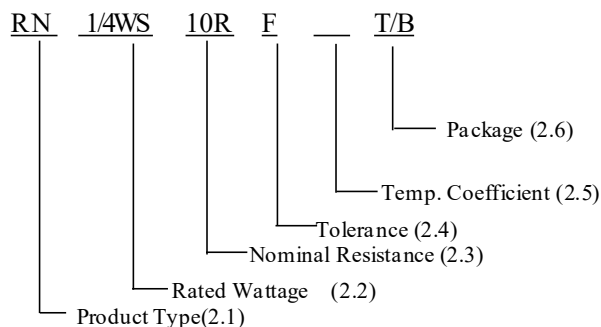

2.1 Product Type

Code	RN
Product Type	Precision Metal Film Resistors

2.2 Rated Wattage code

Code	1/8W	1/4W	1/4WS	1/2W	1/2WS	0.6W	1W	1WL	1WS	2W	2WS	3WS
Rated Power (W)	1/8W	1/4W	1/4W	1/2W	1/2W	0.6W	1W	1W	1W	2W	2W	3W

2.3 Nominal Resistance

Code	10R	10K	100K
Resistance	10Ω	10KΩ	100KΩ

Remark:Ω is its unit which be in accordance with JIS-C6409 article 6 (EIARS-196A) series.

2.4 Resistance tolerance

Code	B	C	D	F	G	J
Tolerance Range	±0.1%	±0.25%	±0.5%	±1%	±2%	±5%

2.5 Temperature Coefficient

_Code	25PPM	50PPM	Nil
ppm/°C	±25ppm/°C	±50ppm/°C	±100ppm/°C

Issued-date: 2025-12-15

Name

Specification Sheet – RN

Revision

B

Page

2

STANDARD MANUAL

2.6 Package

Code	T/B	T/R	T76	R73	NIL
Inner Code	Standard Tape in box	Standard Tape in reel	76 mm width special tape in box	76 mm width special tape in reel	Bulk

Remark : RN Series Resistors are RoHS & Halogen Free Compliant.

3. Rated Power:

Rated power is the value of Max load power specified at the ambient temperature of 70°C, and shall meet the functions of electrical and mechanical performance. When the ambient temperature surpasses above mentioned temperature, the value declines as per following DERATING CURVE.

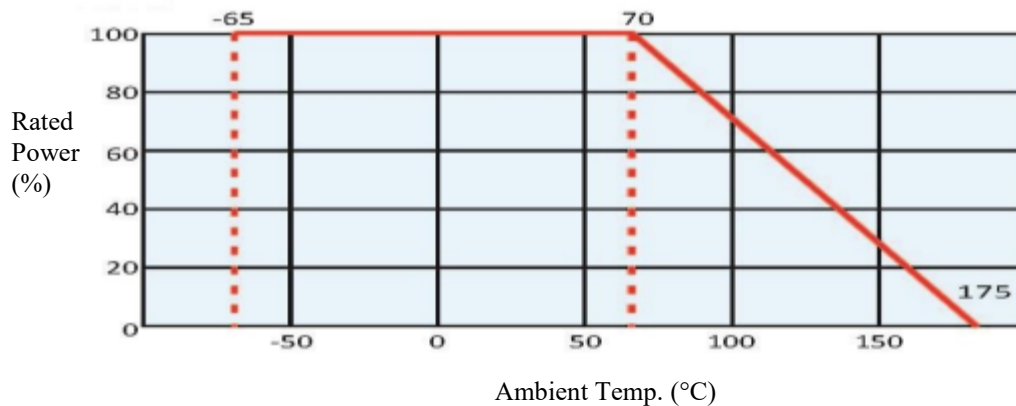

3.1 Rated Voltage:

It is calculated through the following formula:

$$E = \sqrt{P \times R}$$

Where E: rated voltage (V)

P: rated power (W)

R: total nominal resistance (Ω)

Remark: However, in case the voltage calculated exceeds the maximum load voltage, such the maximum load voltage shall be regarded as its rated voltage, means whichever less.

4. Dimension and Structure:

4.1 Dimension:

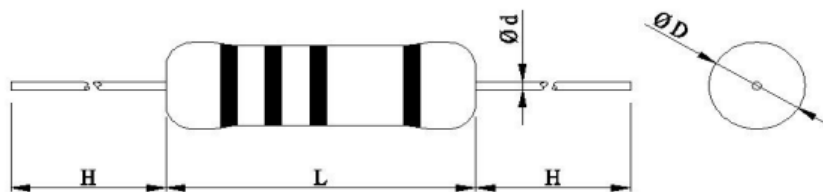

Unit: mm

TYPE	D±1	L±1	H±3	d±0.1	Resistance Range	Max Working Voltage
RN						
1/8W	1.7±0.2	3.7max	28	0.45	10Ω~1MΩ	150V
1/4WS						200V
1/4W						250V
1/2WS	2.4±0.5	6.4	28	0.6	10Ω~2MΩ	300V
0.6W						350V
1/2W	3.5	9	28	0.65	10Ω~2MΩ	350V
1WS	3.5	9	28	0.65	10Ω~2MΩ	350V
1W	4.5	11	28	0.8	10Ω~2MΩ	500V
2WS	4.5	11	28	0.8	10Ω~2MΩ	500V
1WL	5.0	15	28	0.8	10Ω~2MΩ	500V
2W	5.0	15	28	0.8	10Ω~2MΩ	500V
3WS	5.0	15	28	0.8	10Ω~2MΩ	500V

Remark: 1. Too low or too high ohmic value can be supplied only case by case

2. Max Overload Voltage is 2 times of Max Working voltage

3. RN 1W, RN 1WL, RN 2W, RN 2WS, RN 3WS are coated by flameproof paint

4.2 STRUCTURE:

4.2.1 Ceramic Rod:

It is made of Forsterite imported.

4.2.2 Terminal:

Terminal is to be firmly connected with resistors element, both electrically and mechanically, and allow easy soldering.

4.2.3 Coating:

Coating is done by EPOXY insulating paint or flameproof paint(800°C) which is solid enough to be free from looseness, crack and easy breakage. The paint shall be limited within 1mm of lead wires from resistors body while the rated wattage is $\geq 1W$ the paint is limited within 2mm.

4.2.4 Marking:

Marking is made on resistors surface by color coding.

5. Operating Temperature Range: -65°C~175°C

Issued-date: 2025-12-15

Name

Specification Sheet – RN

Revision

B

Page

4

STANDARD MANUAL

6. Test And Requirements:

Test		Test Method	Condition	Criteria															
Mechanical Performance	Terminal tensile	IEC 60115-14.16	To fix the resistor body, a static load of 1kg. is to be gradually applied into the terminal for 10 seconds	Without causing any looseness and fall.															
	Twist withstand		To bend the lead wire at the point of about 6mm from resistor body to 90°, then catch the wire at 1.2 ±0.4mm apart from the bent point end and turn it (clockwise) by 360 degrees perpendicular to the resistor axis at speed of 5 seconds per turn, and do the same counterclockwise again which constitute a whole turn. Repeat the turn 2 times	Without causing any break and looseness.															
Resistance Coefficient:	Temperature	IEC 60115-1 4.8	$T.C \text{ (ppm/}^\circ\text{C)} = \left(\frac{R2 - R1}{R1} \right) \times \left(\frac{1}{T2 - T1} \right) \times 10^6$ where R1: resistance value at reference temperature R2: resistance value at test temp. T1: reference temp. T2: test temp.	It shall be as follows: <table border="1" style="margin-left: 20px;"> <thead> <tr> <th>Code</th> <th>T.C.</th> </tr> </thead> <tbody> <tr> <td>/</td> <td>±100ppm/°C</td> </tr> <tr> <td>T-2</td> <td>±50ppm/°C</td> </tr> <tr> <td>T-9</td> <td>±25ppm/°C</td> </tr> </tbody> </table>	Code	T.C.	/	±100ppm/°C	T-2	±50ppm/°C	T-9	±25ppm/°C							
Code	T.C.																		
/	±100ppm/°C																		
T-2	±50ppm/°C																		
T-9	±25ppm/°C																		
Temperature Cycle		IEC 60115-1 4.19	Following temp. cycles are to be made 5 times and then put at room temp. for one hour <table border="1" style="margin-left: 20px;"> <thead> <tr> <th>Steps</th> <th>Temperature (°C)</th> <th>Time (minutes)</th> </tr> </thead> <tbody> <tr> <td>1st step</td> <td>-65 ± 3</td> <td>30</td> </tr> <tr> <td>2nd step</td> <td>Room temp.</td> <td>3</td> </tr> <tr> <td>3rd step</td> <td>175 ± 3</td> <td>30</td> </tr> <tr> <td>4th step</td> <td>Room temp.</td> <td>3</td> </tr> </tbody> </table>	Steps	Temperature (°C)	Time (minutes)	1 st step	-65 ± 3	30	2 nd step	Room temp.	3	3 rd step	175 ± 3	30	4 th step	Room temp.	3	The resistance value change rate between pre-and-post test shall be within ±0.25%
Steps	Temperature (°C)	Time (minutes)																	
1 st step	-65 ± 3	30																	
2 nd step	Room temp.	3																	
3 rd step	175 ± 3	30																	
4 th step	Room temp.	3																	
Voltage Withstanding		IEC 60115-1 4.7	Resistors are located in a V-shaped metal trough. Applying Max overload voltage (RN 1W, RN 1WL, RN 2WS, RN 2W, RN 3WS: Applying AC 350V, RN 1/4WS: Applying AC 300V) for one minute	The resistance should find no physical damage to the resistors, such as arc, char...etc.															

Issued-date: 2025-12-15

Name

Specification Sheet – RN

Revision

B

Page

5

STANDARD MANUAL

Test	Test Method	Condition	Criteria
Short Time Over Load	IEC 60115-14.13	When the resistors are applied 2.5 times as much as rated voltage for 5 seconds continuously, it shows no evidence of arc, flame...etc. Removing the voltage and place the resistors to the normal condition for 30 minutes,	The resistance value change rate between pre-and-post test shall be within $\pm 0.5\%$.
Insulation Character	IEC 60115-1 4.6	Resistors are located in a V-shaped metal trough. Using the DC 100V or 500V megger instrument 2 poles to clutch either side of lead wires and metal trough	Measuring the Insulation Resistance which shall be over 1000M Ω
Load Life	IEC 60115-14.25	The resistors arrayed are sent into the 70°C oven, applying rated voltage at the cycle of 1.5 hours ON, 0.5 hour OFF for 1000+48-0 hours in total. Then, after removing the voltage, take the resistors out of the oven and left under normal temp. for one hour cooling.	The resistance value change rate between pre-and-post test shall be within $\pm 2\%$.
Moisture-proof Load Life	IEC 60115-14.24	The resistors arrayed are placed into a constant temp./humidity oven at the temp. of $40 \pm 2^\circ\text{C}$ and the humidity of 90~95%, then rated power is applied for 1.5 hours and cut off for 0.5 hour. The similar cycle will be repeated for 1000_{-0}^{+48} hours in total (including cut-off time). Then remove the voltage,taking the resistors out of the oven and leaving them at room temp. for one hour.	The resistance value change rate between pre-and-post test shall be within $\pm 5\%$. There also shall be no evidence of remarkable change on appearance, and the marking shall not be illegible.
Solder-ability	IEC 60115-1 4.17	The leads with flux are dipped in a melted solder of $235 \pm 5^\circ\text{C}$ for 2 seconds,	more than 95% of the circumference of the lead wires shall be covered with solder.
Resistance to Soldering Heat	IEC 60115-1 4.18	Two leads are together dipped in a melted solder of $270 \pm 5^\circ\text{C}$ for 10 ± 1 seconds, or $350 \pm 10^\circ\text{C}$ for 3.5 ± 0.5 seconds, Then remove the resistors and leaving them at room temp. for one hour.	The resistance value change rate between pre-and-post test shall be within $\pm 1\%$.
Nonflammability	JIS - C 5201-4.26	The resistors are applied the power of 16 times the rated wattage for 5 min. (only for RN 1W, RN 1WL, RN 2W, RN 2WS, RN 3WS)	The resistance shall not get flame.

Issued-date: 2025-12-15

Name

Specification Sheet – RN

Revision

B

Page

6

STANDARD MANUAL

7. Others:

7.1 MG Form:

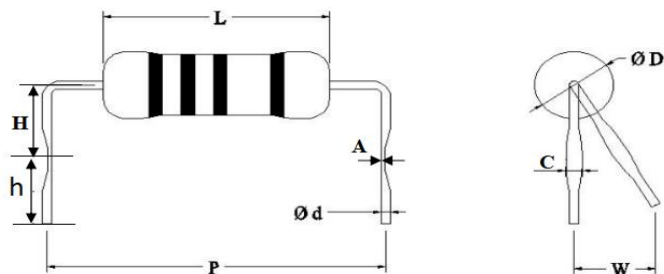

Unit: mm

Wattage	D±1	L±1	P	H	h±1	A±0.1	B±0.05	C±0.2
1/2W,1WS	3.5	9	15±1.5	7±1	4.5	0.23	0.8	1.2
1W,2WS	4.5	11	15±1.5	7±1	4.5	0.25	1	1.4
1WL,2W,3WS	5	15	20±2	10±2	4.5	0.25	1	1.4

7.2 F Form:

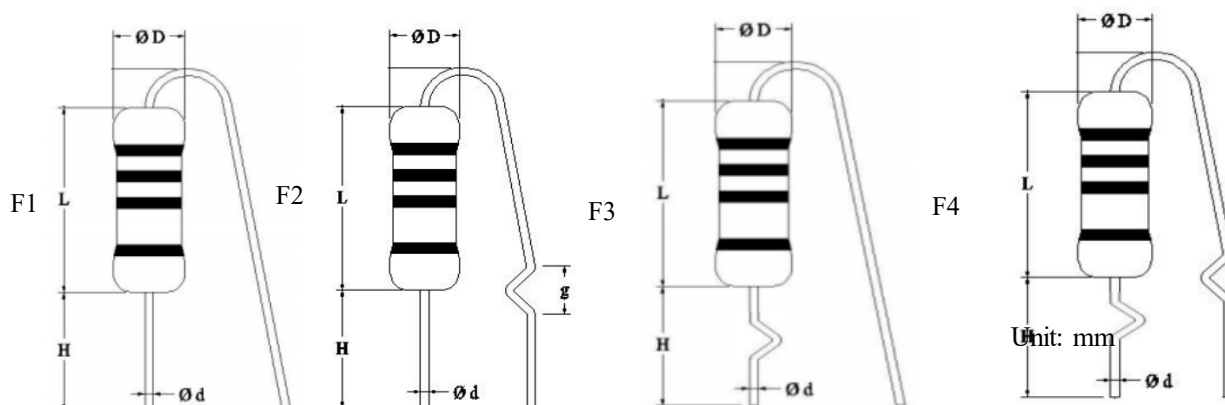

Unit: mm

Wattage	L±1	D±1	A+1/-0.5	Applicable
1/2W,1WS	9	3.5	3.5	F1~F4
1W,2WS	11	4.5	3.5	F1~F4
1WL,2W,3WS	15	5	3.5	F1~F4

7.3MB Form:

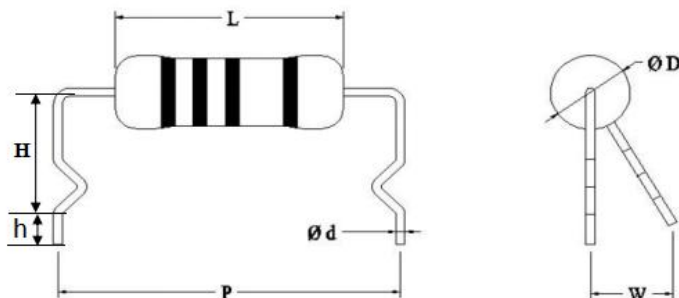

Unit: mm

Wattage	D±1	L±1	P	H±0.5	h + 1/ - 0.5	B±0.05
1/2W,1WS	3.5	9	15±1.5	6.5	2	1
1W,2WS	4.5	11	15±1.5	6.5	2	1
1WL,2W,3WS	5	15	20±2	6.5	2	1

7.4M Form:

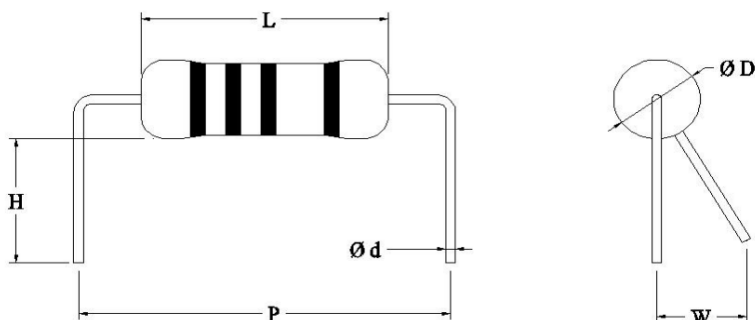

Unit: mm

Wattage	L±1	D±1	P	H±0.5
1/8W、1/4WS	3.7max	1.7±0.2	5±0.5	3.5
1/4W、1/2WS、0.6W	6.4	2.4±0.5	10±1	3.5
1/2W,1WS	9	3.5	15±1.5	3.5
1W,2WS	11	4.5	15±1.5	3.5
1WL,2W,3WS	15	5	20±2	3.5

Issued-date: 2025-12-15

Name

Specification Sheet – RN

Revision

B

Page

8

STANDARD MANUAL

7.5 Taping Specifications :

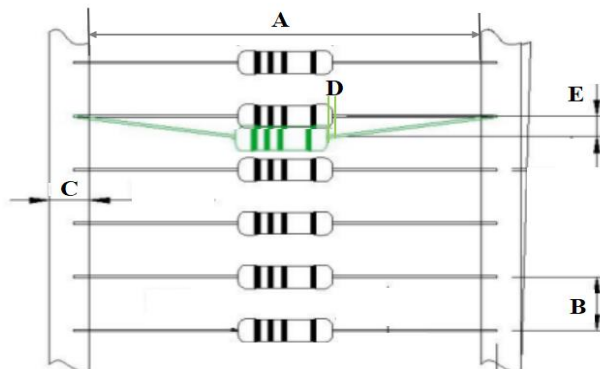

Unit: mm

Wattage	Size	A	B	C±1	D Max	E Max
	Package					
≤1/4W	T26	26^{+1}_0	5 ± 0.5	6	0.6	1.2
	T/B,T/R	52 ± 1	5 ± 0.5	6	0.6	1.2
1/2W,1WS	T/B,T/R	52 ± 1	5 ± 0.5	6	0.6	1.2
1W,2WS	T/B,T/R	63 ± 1	5 ± 1	6	0.6	1.2
1WL,2W,3WS	T/B,T/R	63 ± 1	10 ± 1	6	0.6	1.2
	T76, R76	76 ± 1.5	10 ± 1	6	0.6	1.2

Tape in box

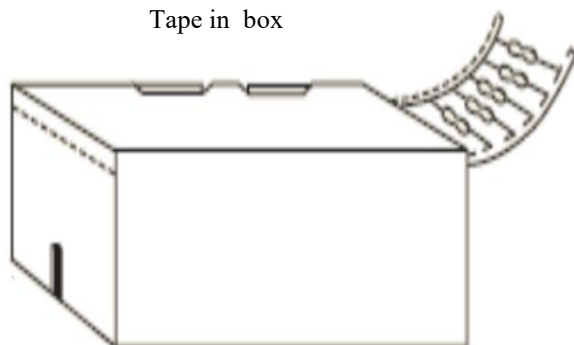

Tape in reel

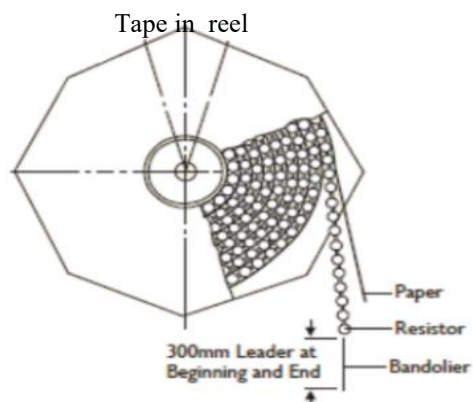

7.6 Radial type lead tapping(PA):

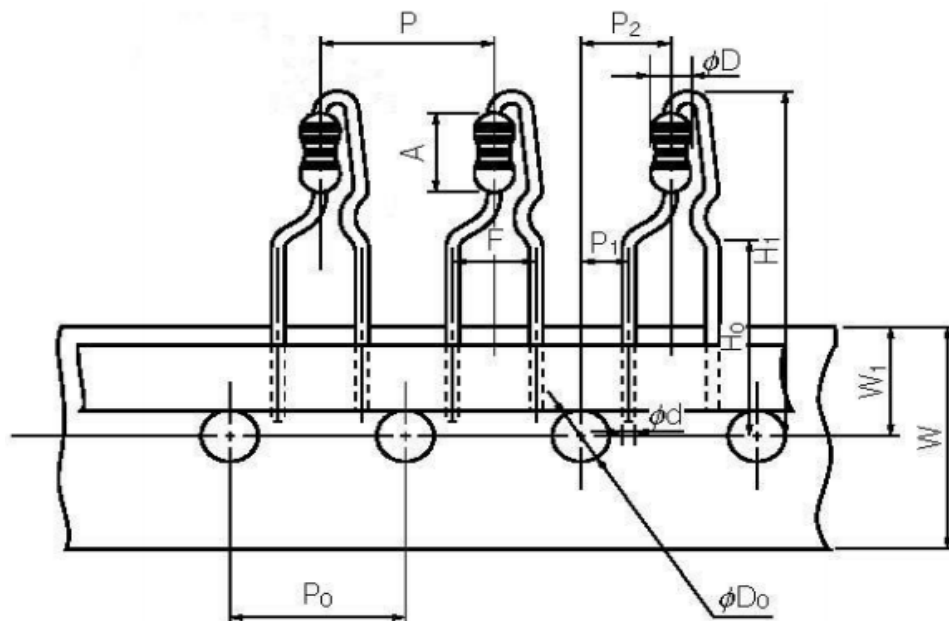

Wattage	P±1	P0±0.3	P1±0.7	P2±1	F±0.8	W±0.5	W1±0.5	H1max	H0±0.5	φD0±0.2	A±1	φd±0.1	φD±1	REMARK
1/4W,1/2WS 0.6W	12.7	12.7	3.85	6.35	5	18	9	32	16	4	6.4	0.6	2.4±0.5	
1/2W,1WS	12.7	12.7	3.85	6.35	5	18	9	32	16	4	9	0.65	3.5	
1W,2WS	12.7	12.7	3.85	6.35	5	18	9	38	16	4	11	0.8	4.5	
1WL,2W, 3WS	12.7	12.7	3.85	6.35	5	18	9	38	16	4	15	0.8	5	

8.Storage Conditions:

The resistors with appropriate package would have a preservative duration of 1 year, under the following conditions.

T=5°C ~ 35°C

H=40% ~ 75%

9. Precautions In Use:

To prevent electric corrosion risk (10 ppm defect rate over 1 year use).the resistance value over 100KΩ should be limited at 50V when ambient temperature and humidity is higher than 85°C/85%.

Issued-date: 2025-12-15

Name

Specification Sheet – RN

Revision

B

Page

10

STANDARD MANUAL