

1.Part Number Description:

A **NP0** **151** **J** **1H** **R13** **TR**

① ② ③ ④ ⑤ ⑥ ⑦

① Type

Symbol	Type
A	Axial

② Temperature Characteristic

Temp. Charact.	Temperature Range	Capacitance Change
NPO	-55 ~ 125°C	0 ± 30 ppm/°C
X5R	-55 ~ 85°C	±15%
X7R	-55 ~ 125°C	±15%
Y5V	-30 ~ 85°C	+22%, -82%
Z5U	+10 ~ 85°C	+22%, -56%

③ Capacitance Value

Symbol	Cap. Value
060	6pF
6R8	6.8pF
120	12pF
471	470pF
222	2200pF
104	100000pF

④ Capacitance Tolerance

Symbol	Cap. Tol.
C	±0.25pF
D	±0.5pF
F	±1%
G	±2%
J	±5%
K	±10%
M	±20%
Z	+80%, -20%

⑤ Rated Voltage

Symbol	Rated Voltage
0J	DC 6.3V
1A	DC 10V
1C	DC 16V
1E	DC 25V
1H	DC 50V
2A	DC 100V
2B	DC 200V
2E	DC 250V
2H	DC 500V

⑥ Size

Check point 4

⑦ Packing or Pitch

Symbol	Packing
TA	AMMO
TR	REEL

2. 特点 Feature

*体积小，容量大，适合自动安装的卷（编）带包装。

Miniature size, large capacitance, tape and reel packaging suitable for auto-placement

*环氧树脂封装，从而具有优良的防潮性能、机械强度及耐热性。

Epoxy resin coating creates excellent performance in humidity resistance, mechanical strength and heat resistance

*工业生产标准尺寸及多种脚型产品。

Standard size, various lead configuration

介质种类 Dielectric Type	I类介质 Class I	II类介质 Class II		
介质材料 Dielectric Material	温度补偿型 Temperature Compensating	X7R/X5R(B)	Z5U(E)	Y5V(Y/F)
电气性能 Electrical Properties	<p>电气性能最稳定，几乎不随温度、电压和时间的变化而变化。</p> <p>The electrical properties is the most stable one and has little change with temperature, voltage and time.</p>	<p>具有较高的介电常数，容量可做到比I类电容器高，具有稳定的温度特性。</p> <p>X7R material has high dielectric constant, and its capacitance is higher than class I. These capacitors are classified as having a semi-stable T.C..</p>	<p>温度特性介于X7R和Y5V之间，容量稳定性相对较差，对温度、电压等条件较敏感。</p> <p>Temperature characteristic is between that of X7R and Y5V. The capacitance is unstable and sensible to temperature and voltage.</p>	<p>介电常数最大，但温度特性较差，对温度、电压等条件较敏感。</p> <p>Y5V material has highest dielectric constant. Its capacitance and dissipation is sensible to temperature and voltage.</p>
应用 Application	<p>适用于低损耗，稳定性要求高的高频电路，如滤波器、振荡器和定时电路等。</p> <p>Used in applications where low-losses and high-stability are required, such as filters, oscillators, and timing circuits so on.</p>	<p>适用于容量范围广，稳定性要求不高的电路中，如隔直、耦合、旁路及鉴频等电路中。</p> <p>Used over a wide temperature range, such in these kinds of circuits, DC-blocking, coupling, bypassing, frequency discriminating etc.</p>	<p>适用于要求大容量，使用温度范围接近于室温的旁路、耦合等，及低直流偏压电路中。</p> <p>Ideally suited for bypassing and coupling application circuits operating with low DC bias in the environment approaching to room temperature.</p>	<p>适用于要求大容量，温度变化不大的电路中</p> <p>Used over a moderate temperature range in application where high capacitance is required.</p>
容量范围 Available capacitance range	0.5pF~0.1uF	100pF~22uF	1nF~10uF	

3.通用型引线MLCC可靠性及测试方法

Reliability and Test Method for General Leaded MLCC

项目 Item	技术要求 Technical Specification		测试方法和备注 Test Method and Remarks			
容量 Capacitance (C)	I 类 Class I	应符合指的误差级别 With in the specified tolerance.	标称容量 Capacitance	测试频率 Measuring Frequency	测试电压 Measuring Voltage	
			<1000pF	1MHZ±10%	1.0V	
			≥1000pF	1KHZ±10%		
	II 类 Class II	应符合指的误差级别 Wit hi n the specified tolerance.	对于 II 类电容器, 测试前应先预处理 For class II capacitor, pr e treatment should be taken before the test			
			测试频率 Measuring Frequency	测试电压 Measuring voltage		
			<10uF 1KHZ±10% ≥10uF 120Hz±10%	B: 1.0±0.2V	M/E/Y(F) <1uF/0.5V ≥1uF/1.0V	
损耗角正切 Dissipation Factor (DF)	I 类 Class I	C, R≥50pF DF≤0.15% C, R<50pF DF≤1.5【(150/C, R)+7】×10 ⁻⁴	标称容量 Capacitance	测试频率 Measuring Frequency	测试电压 Measuring Voltage	
			≤1000pF	1MHZ±10%	1.0V	
			>1000pF	1KHZ±10%		
	II 类 Class II	B 100V<1uF, DF≤3.5% 50V≥1uF, DF≤5.5% 25V≥10uF, DF≤7.5% 16V≥10uF, DF≤10% 10V≥10uF, DF≤15%	≤10uF 测试频率:1KHZ±10%; 测试电压: 1.0V ≥10uF 测试频率:120Hz±10%;测试电压: 1.0V Measuring Frequency Measuring voltage			
			E/ Y (F)	测试频率 Measuring Frequency 测试电压: 0.5V Measuring voltage		
			(C, R≥1uF) ≤15%(C≥10uF, DF ≤15%,R≥1uF)	测试频率 Measuring Frequency 测试电压: 1.0V Measuring voltage		
绝缘电阻 Insulation Resistance	I 类 Class I	见附件 1 See the attachment1	测试电压:额定电压 Measuring voltage: Rated voltage 测试时间: 60±5 秒 Du ration: 60±5S			
	II 类 Class II	见附件 1 See the attachment1				

Attachment 1:

介质类别 Dielectric Type	I 类 Class I		II 类 Class II	
容量 Capacitance	$\leq 10\text{nF}$	$> 10\text{nF}$	$\leq 25\text{nF}$	$> 25\text{nF}$
绝缘电阻 Insulation Resistance	$\geq 10\text{G}\Omega$	$\geq 100/\text{C}\Omega\text{F}$	$\geq 4\text{G}\Omega$	$\geq 100/\text{C}\Omega\text{F}$

1) "C"代表此产品的容量 "C" stands for product capacitance

2) 举例 For example:

-AX7R104K1HR13TA (Ceramic Cap Axial,0603,X7R,50V,0.1uF,±10%)

$$\text{IR} \geq 100 \Omega \text{F}/\text{C} = 100 \Omega \text{F}/(0.1 * 10^{-6} \text{F}) = 10^9 \Omega = 1\text{G}\Omega$$

-AX7R224K1HR15TA (Ceramic Cap Axial,0805,X7R,50V,0.22uF,±10%)

$$\text{IR} \geq 100 \Omega \text{F}/\text{C} = 100 \Omega \text{F}/(0.22 * 10^{-6} \text{F}) = 454.5 * 10^6 \Omega = 0.4545\text{G}\Omega$$

-AX7R105K1HR15TA (Ceramic Cap Axial,0805,X7R,50V,1uF,±10%)

$$\text{IR} \geq 100 \Omega \text{F}/\text{C} = 100 \Omega \text{F}/(1 * 10^{-6} \text{F}) = 100 * 10^6 \Omega = 100\text{M}\Omega$$

项目 Item	技术要求 Technical Specification		测试方法和备注 Test Method and Remarks
耐电压 Withstandi-ng Voltage	不应有介质被击穿或损伤 No breakdown or damage.		端之间B e t w e e n term in a l s 测试电压Measuring Voltage: 持续时间: 5±1秒Duration: 5±1s I类: 300%额定电压 Class I:300% Rated voltage II类: U,R≤500V额定电压2.5UR Class II: U, 2.5 UR R rated voltage 500 v or less II类: U,R>500V≤1000V额定电压1.5UR Class II: U R > 1.5 UR 500 v rated voltage 1000 v or less II类: U,R>1000V额定电压1.2UR Class II: U R > 1.2 UR rated voltage 1000 v I类充/放电电流不应超过50mA I kind of charge/discharge current should not exceed 50 ma II类小尺寸芯片充/放电电流不应超过30mA Class II small size chips charge/discharge current should not exceed 30 ma II类充/放电电流不应超过50mA Class II charge/discharge current should not exceed 50 ma
			端子与外装间Between terminals and body: 施加电压: 2.5UR 持续时间: 1~5s Voltage: 2.5 times rated voltage Duration: 1~5s 金属制小球法 Small metallic ball method 将电容器本体插入盛满直径为1mm的金属小球的容器中, 但保留距端头处2mm的 本体不插入。试验电压施加在短路回路端子和金属小球之间。 Small metallic balls with 1mm diameters shall be put in a vessel and the test capacitor shall be submerged except 2mm from the top of its component body and the terminals. The test voltage shall be applied between the short-circuited terminals and the metallic balls.
可焊性 Solder ability	上锡率应大于75% Lead wire shall be at least 75% covered with a new solder coating.		将电容器引线浸入含有25%松香的酒精溶液中, 然后浸入温度为: 230±5℃的金属焊锡(63Sn/37Pb)中 2±0.5秒, 注意: 电容器本体底面距离锡面约1.5~2mm, The terminal of capacitor is dipping into a 25% rosin solution of ethanol and then into molten solder(63Sn/37Pb) of 230±5℃ for 2±0.5s. In both cases the depth of dipping is up to about 1.5~2mm from the terminal body.
耐焊接热 Resistance to Soldering Heat	项目 Item	ΔC/C≤	锡温: 260±5℃ 时间: 10±1s Solder temperature: 260±5℃ Duration: 10±1s 浸入条件: 将电容器插入厚度为1.6mm, 孔径为1.0mm的PC板。 Immersed conditions: Inserted into the PC board (with t=1.6mm, hole=1.0mm diameter) 对于I类介质, 试验后, 应在标准条件下恢复4~24小时后才测试。 Recovery: For class I, 4 to 24 hours of recovery under the standard condition after test. 对于II类介质, 在试验前应先进行如下预处理: 150(-10,+0)℃, 1小时, 接着在标准条件下恢复48±4小时。 Preconditioning(Class II): 1 hour of preconditioning at 150(-10,+0)℃, followed by 48±4 hours of recovery under the standard condition. 恢复: 对于II类介质试验后, 应在标准条件下恢复48±4小时后才测试。 Recovery (Class II) : 48±4 hours of recovery under the standard condition after test.
	Class I	± 2.5% or ± 0.25pF	
	B	±10%	
	E / Y(F)	±20%	
	外观无可见损伤 No significant abnormality in appearance.		

以上所示“标准条件”解释如下:

温度: 5~35℃, 湿度: 45~85%, 气压: 86~106kPa

* Note on standard condition: " standard condition " referred to herein should be defined as follows:

5 to 35°C of temperature, 45 to 75% of relative humidity, and 86 to 106kPa of atmospheric pressure.

4.尺寸、工作电压及容量关系表

Size Code and Voltage VS Capacitance

尺寸规格	尺寸大小(mm)				工作电压	
	Lmax	Dmax	F(±0.6)			d(±0.05)
0603(R13)	5.0	3.0	5.08	10.00	0.45	25V 50V 100V
0805(R15)	5.0	3.0	5.08	10.00	0.45	25V 50V 100V
1206(R18)	5.0	3.0	5.08	10.00	0.45	25V 50V 100V
1210(R10)	5.5	3.0	7.50	10.00	0.45	25V 50V 100V

5.外形尺寸 External Dimensions

5.1 Bulk Products:

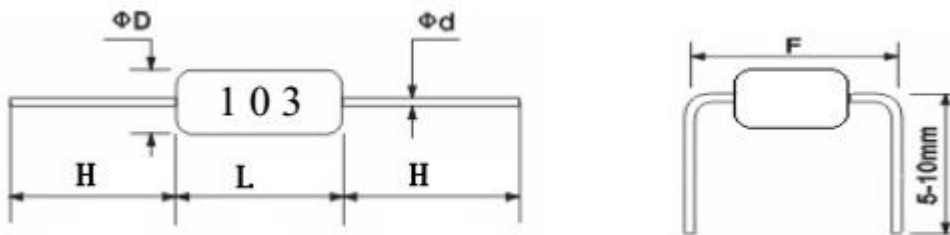

尺寸代码	H(mm)	D(mm)	Φd(mm)	L(mm)	F(mm) ±0.6		
0603	≤5.0	≤3.0	0.45±0.05	≥20	5.08	7.50	10.0
0805	≤5.0	≤3.0	0.45±0.05	≥20	5.08	7.50	10.0

5.2 编带 Tape

单位 Unit: mm

编带方式 Tape Style	L	Z	L1-L2
编带内距: 26 Tape Width:	26±1.5	0.8	1.0
编带内距: 52 Tape Width:	52 +2.0 -1.0	1.2	

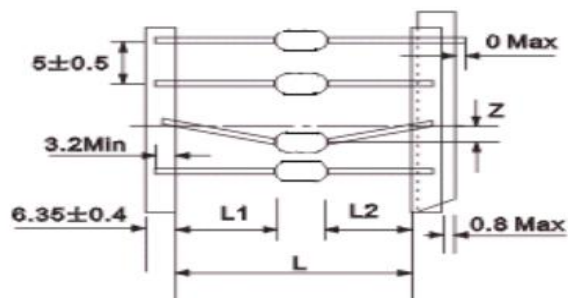

5.3 卷带包装 Tape and Reel Packaging:

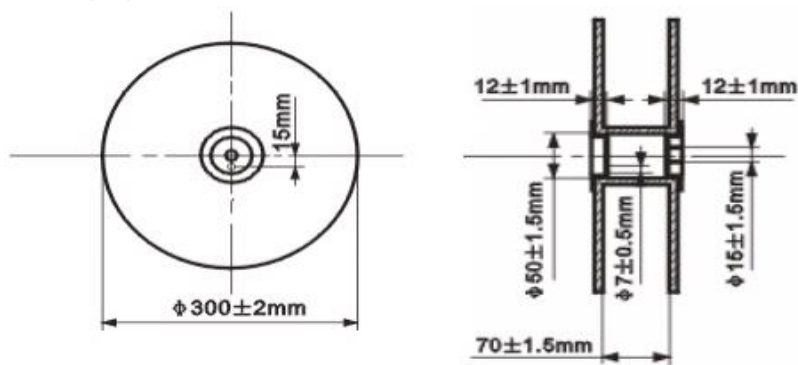

5.4 盒带包装 Ammo Packaging

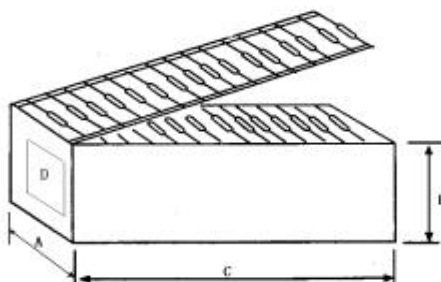

尺寸规格 Size Code	编带方式 Tape Style	A ± 5mm	B ± 5mm	C ± 5mm	D
R13	P52	76	72	263	貼标签 Lable
R13	P26	60	72	266	
R15/R18/R10	P52	83	80	266	
R15/R18/R10	P26	60	72	266	

5.5 包装数量 Packaging Quantily:

尺寸规格 Size Code	卷带包装 Tape and Reel	盒带包装 Ammo	散包装 Bulk
R13	5000	5000	1000
R15	5000	5000	1000
R18	5000	5000	1000
R10	5000	5000	1000