

2. Dimensions and Technical Parameter:

Fig.1($\phi 4 \sim \phi 10$)

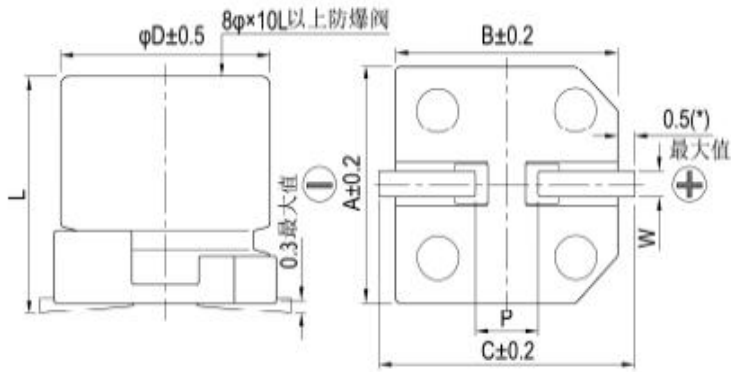

Unit: mm

Fig.2($\geq \phi 12.5$)

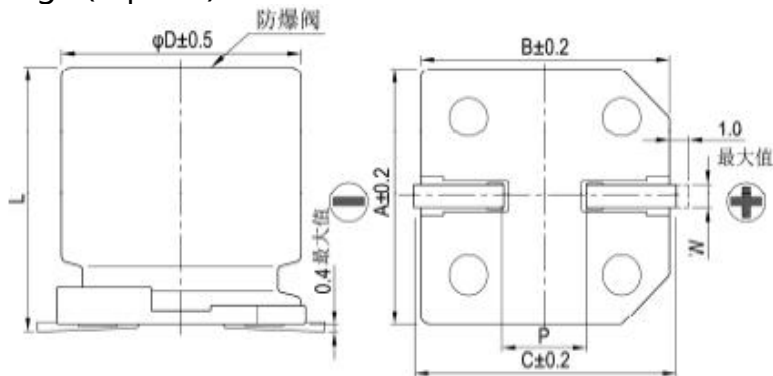

Unit: mm

ϕD	L	A	B	C	P ± 0.2	W	Fig.No.
4	5.4 -0.3/+0.5	4.3	4.3	5.0	1.0	0.5~0.9	Fig.1
5	5.4 -0.3/+0.5	5.3	5.3	6.0	1.5	0.5~0.9	Fig.1
6.3	5.4&5.7 -0.3/+0.4	6.6	6.6	7.2	2.1	0.5~0.9	Fig.1
6.3	5.8 ± 0.3	6.6	6.6	7.2	2.1	0.5~0.9	Fig.1
6.3	7.7 -0.3/+0.5	6.6	6.6	7.2	2.1	0.5~0.9	Fig.1
8	6.5 ± 0.5	8.3	8.3	9.1	3.1	0.8~1.1	Fig.1
8	10.2-0.3/+0.8 or 10.5 ± 0.5	8.3	8.3	9.1	3.1	0.8~1.1	Fig.1
10	10.2-0.3/+0.8 or 10.5 ± 0.5	10.3	10.3	11.1	4.5	0.8~1.3	Fig.1
12.5	13.5 ± 0.5	13	13	13.7	4.4	1.0~1.4	Fig.2
16	21.5 ± 0.5	17	17	18.0	6.4	1.1~1.4	Fig.2
18	16.5 ± 0.5	19	19	20.0	6.4	1.1~1.4	Fig.2

Technical Parameter:

Customer P/N	Aillen P/N	Cap. (μF)	Cap. Tol.	Rate Volt. (VDC)	Surge Volt. (VDC)	Oper. Temp. ($^{\circ}C$)
/	CAE476M1VHUEEE4TR6	47	$\pm 20\%$	35	40.3	-55~105
Case Size D*L (mm)	Leakage Current (μA)max	Tan δ 120Hz Max	ESR 100kHz Max(Ω)	R.C 100kHz (mA rms)	Load Life (hours)	Note
6.3x5.4	16.45	0.12	1.1	115	2000	