

1. Application

This specification applies to polar Aluminum electrolytic capacitor (foil type) used in electronic equipment.

Designed capacitor's quality meets IEC60384.

2. Part Number System

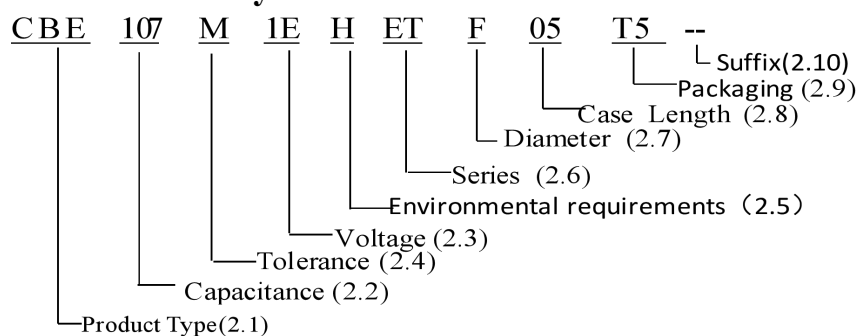

2.1 Product Type

Code	CBE
Product Type	Radial

2.2 Capacitance code

Code	105	106	107
Capacitance (μF)	1.0	10	100

2.3 Rated voltage code

Code	0J	1A	1C	1E	1V	1H
Voltage (WV)	6.3	10	16	25	35	50

2.4 Capacitance tolerance

Code	M	V
Tolerance Range	±20%	-10%~+20%

2.5 Environmental requirements

Code	R	H
Environmental requirements	ROHS Requirements Remark:Product Set PVC Sleeve	ROHS Requirements and Halogen Free Remark:Product Set PET Sleeve

2.6 **Products Series Code**

Code	ET
Series	CD11ET

2.7 **Diameter**

Code	B	C	D	E	F
Diameter	3	4	5	6.3	8

2.8 **Case length**

(1) When the code is number, it represent the actual height.(e.g. The code 07 indicates that the height is 7mm; The code 10 indicates that the height is 10mm)

(2) When the code is number + alphabet, please check the following the table:

Code	1A	1B	1C	1D	2A	3A
Case Length(mm)	11.5	12.5	13.5	14.5	21.5	31.5

2.9 **Packaging**

Code	RR	R2	T2	TB	T3	T5
Packaging	Bulk	F8,Lead Pitch=2. 5mm, Bulk	Lead Pitch=2.0mm Taping	Lead Pitch=2.5mm Taping	Lead Pitch=3.5mm Taping	Lead Pitch=5.0mm Taping
Code	T7		CA	CB	CC	CD
Packaging	Lead Pitch=7.5mm Taping		Cutting the feet long=3.0mm	Cutting the feet long=3.5mm	Cutting the feet long=4.0mm	Cutting the feet long=4.5mm

Note: The length of the product's cut feet starts from A=3.0mm. Every time it increases by 0.5mm, the English word is pushed forward one place, as shown in the following table:

Cutting length(mm)	Code
3.0±0.5	CA
3.5±0.5	CB
4.0±0.5	CC
4.5±0.5	CD
5.0±0.5	CE
6.0±0.5	CG
And so on-----	

2.10 **Suffix: Inner Code**

Issued-date: 2022-11-05	Name	Specification Sheet – CD11ET		
Revision	B		Page	2
STANDARD MANUAL				

3. Construction:

Single ended type to be produced to fix the terminals to anode and cathode foil, and wind together with paper, and then wound element to be impregnated with electrolyte will be enclosed in an aluminum case. Finally sealed up tightly with end seal rubber, then finished by putting on the vinyl sleeve.

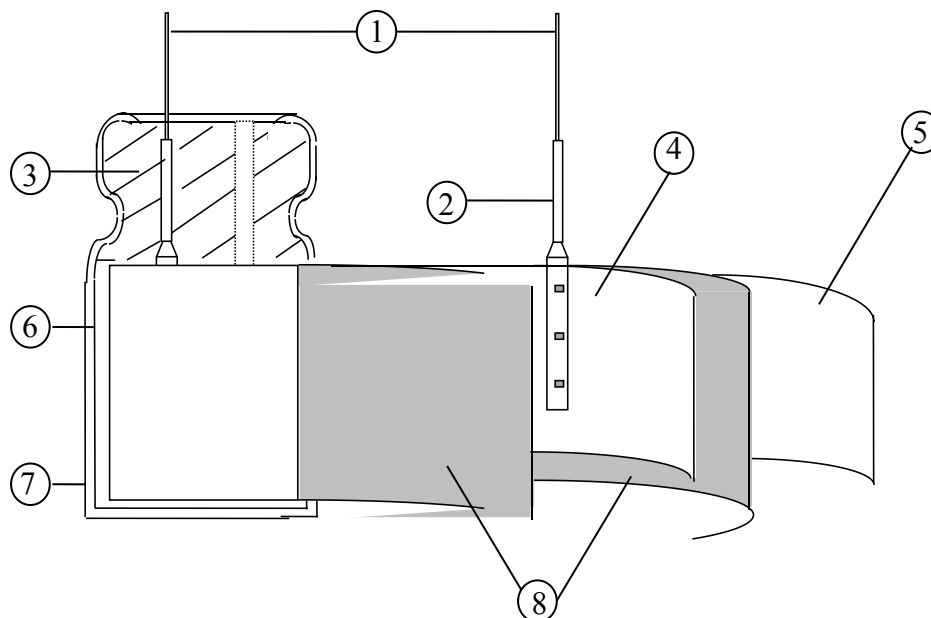

No	Component	Material
1	Lead line	Tinned CP wire (Pb Free)
2	Terminal	Aluminum wire
3	Sealing Material	Rubber
4	Al-Foil (+)	Formed aluminum foil
5	Al-Foil (-)	Etched aluminum foil or formed aluminum foil
6	Case	Aluminum case
7	Sleeve	PET
8	Separator	Electrolyte paper

4. Characteristics

Standard atmospheric conditions

Unless otherwise specified, the standard range of atmospheric conditions for making measurements and tests is as follows:

Ambient temperature	: 15°C to 35°C
Relative humidity	: 45% to 85%
Air Pressure	: 86kPa to 106kPa

If there is any doubt about the results, measurement shall be made within the following conditions:

Ambient temperature	: 20°C ± 2°C
Relative humidity	: 60% to 70%
Air Pressure	: 86kPa to 106kPa

Operating temperature range

The ambient temperature range at which the capacitor can be operated continuously at rated voltage is (6.3~50WV) -40°C to 105°C.

As to the detailed information, please refer to table 1.

Table 1

Item		PERFORMANCE														
4.1	Nominal capacitance (Tolerance)	<p><Condition> Measuring Frequency : 120Hz±12Hz Measuring Voltage : Not more than 0.5V Measuring Temperature : 20±2°C</p> <p><Criteria> Shall be within the specified capacitance tolerance.</p>														
4.2	Leakage Current	<p><Condition> After DC Voltage is applied to capacitors through the series protective resistor (1kΩ ± 10Ω) so that terminal voltage may reach the reacted use voltage. The leakage current when measured in 2 minutes shall not exceed the values of the following equation.</p> <p><Criteria> $I \leq 0.01CV$ or 3 (μA) whichever is greater.</p> <p>I: Leakage current (μA) C: Capacitance (μF) V: Rated DC working voltage (V)</p>														
4.3	Tan δ	<p><Condition> See 4.1 Nominal capacitance, for measuring frequency, voltage and temperature.</p> <p><Criteria></p> <table border="1"> <tr> <td>Working voltage (v)</td> <td>6.3</td> <td>10</td> <td>16</td> <td>25</td> <td>35</td> <td>50</td> </tr> <tr> <td>tan δ(max.)</td> <td>0.28</td> <td>0.24</td> <td>0.20</td> <td>0.16</td> <td>0.13</td> <td>0.12</td> </tr> </table> <p>For capacitance value >1000uF, add 0.02per another 1000uF</p>	Working voltage (v)	6.3	10	16	25	35	50	tan δ(max.)	0.28	0.24	0.20	0.16	0.13	0.12
Working voltage (v)	6.3	10	16	25	35	50										
tan δ(max.)	0.28	0.24	0.20	0.16	0.13	0.12										
4.4	Rated voltage (WV) Surge voltage (SV)	<table border="1"> <tr> <td>WV (V.DC)</td> <td>6.3</td> <td>10</td> <td>16</td> <td>25</td> <td>35</td> <td>50</td> </tr> <tr> <td>SV (V.DC)</td> <td>8.0</td> <td>13</td> <td>20</td> <td>32</td> <td>44</td> <td>63</td> </tr> </table>	WV (V.DC)	6.3	10	16	25	35	50	SV (V.DC)	8.0	13	20	32	44	63
WV (V.DC)	6.3	10	16	25	35	50										
SV (V.DC)	8.0	13	20	32	44	63										

4.5

Temperature
characteristic
IEC-60384-4 4.12

<Condition>

STEP	Testing Temperature(°C)	Time
1	20±2	Time to reach thermal equilibrium
2	-40 ±3	Time to reach thermal equilibrium
3	20±2	Time to reach thermal equilibrium
4	105±2	Time to reach thermal equilibrium
5	20±2	Time to reach thermal equilibrium

<Criteria>

- a. At +105°C, capacitance shall be within ±20% of their origin at +20°C, measured capacitance, tan δ shall be within limit of 4.3.
The leakage current value at +105°C shall not more than 8 times the specified value.
- b. At step 5, tan δ shall be within the limit of 4.3.
The leakage current value shall not more than the specified value.
- c. At -40°C, impedance (Z) ratio shall not exceed the value of the following table.

Rated Voltage (V)	6.3	10	16	25	35	50
Z-25°C/Z +20°C	4	4	3	2	2	2
Z-40°C/Z +20°C	8	7	5	3	3	3

- d. Capacitance, tan δ, and impedance shall be measured at 120Hz.

4.6

Terminal
Strength
IEC-60384-4 4.4

<Condition>

Tensile strength of terminals
Fixed the capacitor, applied force to the terminal in lead out direction for 10±1 seconds.
Bending strength of terminals
Fixed the capacitor, applied force to bent the terminal (1~4 mm from the rubber) for 90° within 2~3 seconds, and then bent it for 90° to its original position within 2~3 seconds.

Diameter of lead wire	Tensile force N (kgf)	Bending force N (kgf)
0.5mm and less	5 (0.51)	2.5 (0.25)
Over 0.5mm to 0.8mm	10 (1.0)	5 (0.51)

<Criteria>

No noticeable changes shall be found, no breakage or looseness at the terminal.

Issued-date: 2022-11-05

Name

Specification Sheet – CD11ET

Revision

B

Page

6

STANDARD MANUAL

4.7	Load Life test IEC-60384-4 4.13	<p><Condition> According to IEC60384-4No.4.13 methods, The capacitor is stored at a temperature of 105±2°C with DC bias voltage plus the rated ripple current for 1000+48/0 hours. (The sum of DC and ripple peak voltage shall not exceed the rated working voltage) Then the product should be tested after 16 hours recovering time at atmospheric conditions. The result should meet the following table:</p> <p><Criteria> The characteristic shall meet the following requirements.</p> <table border="1" data-bbox="564 696 1412 871"> <tr> <td>Leakage current</td> <td>Value in 4.2 shall be satisfied</td> </tr> <tr> <td>Capacitance Change</td> <td>Within ±20% of initial value.</td> </tr> <tr> <td>tan δ</td> <td>Not more than 200%of the specified value.</td> </tr> <tr> <td>Appearance</td> <td>There shall be no leakage of electrolyte.</td> </tr> </table>	Leakage current	Value in 4.2 shall be satisfied	Capacitance Change	Within ±20% of initial value.	tan δ	Not more than 200%of the specified value.	Appearance	There shall be no leakage of electrolyte.
Leakage current	Value in 4.2 shall be satisfied									
Capacitance Change	Within ±20% of initial value.									
tan δ	Not more than 200%of the specified value.									
Appearance	There shall be no leakage of electrolyte.									
4.8	Shelf Life test IEC-60384-4 4.17	<p><Condition> The capacitors are then stored with no voltage applied at a temperature of 105±2°C for 1000+48/0 hours. Following this period the capacitors shall be removed from the test chamber and be allowed to stabilized at room temperature for 4~8 hours. Next they shall be connected to a series limiting resistor(1k±100Ω) with D.C. rated voltage applied for 30min. After which the capacitors shall be discharged, and then, tested the characteristics.</p> <p><Criteria> The characteristic shall meet the following requirements.</p> <table border="1" data-bbox="526 1263 1412 1438"> <tr> <td>Leakage current</td> <td>Value in4.2 shall be satisfied</td> </tr> <tr> <td>Capacitance Change</td> <td>Within ±20% of initial value.</td> </tr> <tr> <td>tan δ</td> <td>Not more than 200%of the specified value.</td> </tr> <tr> <td>Appearance</td> <td>There shall be no leakage of electrolyte.</td> </tr> </table> <p>Remark: If the capacitors are stored more than 1 year, the leakage current may increase. Please apply voltage through about 1KΩ resistor, if necessary.</p>	Leakage current	Value in4.2 shall be satisfied	Capacitance Change	Within ±20% of initial value.	tan δ	Not more than 200%of the specified value.	Appearance	There shall be no leakage of electrolyte.
Leakage current	Value in4.2 shall be satisfied									
Capacitance Change	Within ±20% of initial value.									
tan δ	Not more than 200%of the specified value.									
Appearance	There shall be no leakage of electrolyte.									

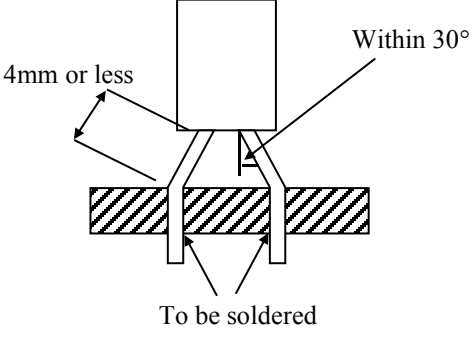
<p>4.9</p>	<p>Surge test IEC-60384-4 4.9</p>	<p><Condition> Test temperature: 15~35°C Series resistor: $R = \frac{100 \pm 50}{C}$ R : protective resistor (KΩ) C : nominal capacitance (μF) Test voltage: Surge voltage item 4.4 No. of cycles: 1000cycles Each cycles lasts for 6±0.5min “ON” for 30±5 s “OFF” for 5±0.5min.</p> <p><Criteria></p> <table border="1"> <tr> <td>Leakage current</td> <td>Not more than the specified value.</td> </tr> <tr> <td>Capacitance Change</td> <td>Within ±15% of initial value.</td> </tr> <tr> <td>tan δ</td> <td>Not more than the specified value.</td> </tr> <tr> <td>Appearance</td> <td>There shall be no leakage of electrolyte.</td> </tr> </table> <p>Attention: This test simulates over voltage at abnormal situation, and not be hypothesizing that over voltage is always applied.</p>	Leakage current	Not more than the specified value.	Capacitance Change	Within ±15% of initial value.	tan δ	Not more than the specified value.	Appearance	There shall be no leakage of electrolyte.
Leakage current	Not more than the specified value.									
Capacitance Change	Within ±15% of initial value.									
tan δ	Not more than the specified value.									
Appearance	There shall be no leakage of electrolyte.									
<p>4.10</p>	<p>Vibration test IEC-60384-4 4.8</p>	<p><Condition> The following conditions shall be applied for 2 hours in each 3 mutually perpendicular directions. Vibration frequency range : 10Hz ~ 55Hz Peak to peak amplitude : 1.5mm Sweep rate : 10Hz ~ 55Hz ~ 10Hz in about 1 minute</p> <p>Mounting method: The capacitor with diameter greater than 12.5mm or longer than 25mm must be fixed in place with a bracket.</p>  <p><Criteria> After the test, the following items shall be tested:</p> <table border="1"> <tr> <td>Inner construction</td> <td>No intermittent contacts, open or short circuiting No damage of tab terminals or electrodes.</td> </tr> <tr> <td>Appearance</td> <td>No mechanical damage in terminal. No leakage of electrolyte or swelling of the case. The markings shall be legible.</td> </tr> </table>	Inner construction	No intermittent contacts, open or short circuiting No damage of tab terminals or electrodes.	Appearance	No mechanical damage in terminal. No leakage of electrolyte or swelling of the case. The markings shall be legible.				
Inner construction	No intermittent contacts, open or short circuiting No damage of tab terminals or electrodes.									
Appearance	No mechanical damage in terminal. No leakage of electrolyte or swelling of the case. The markings shall be legible.									

4.11	Solderability Test IEC-60384-4 4.6	<p><Condition> The capacitor shall be tested under the following conditions: Soldering temperature : 245±3°C Dipping depth : 2mm Dipping speed : 25±2.5mm/s Dipping time : 3±0.5s</p> <p><Criteria></p> <table border="1" data-bbox="563 640 1402 707"> <tr> <td>Coating quality</td> <td>A minimum of 95% of the surface being immersed</td> </tr> </table>	Coating quality	A minimum of 95% of the surface being immersed						
Coating quality	A minimum of 95% of the surface being immersed									
4.12	Resistance to solder heat Test IEC-60384-4 4.5	<p><Condition> Terminals of the capacitor shall be immersed into solder bath at 260±5°C for 10±1seconds or 400±10°C for 3~4 seconds to 1.5~2.0mm from the body of capacitor.</p> <p>Then the capacitor shall be left under the normal temperature and normal humidity for 1~2 hours before measurement.</p> <p><Criteria></p> <table border="1" data-bbox="563 1115 1402 1294"> <tr> <td>Leakage current</td> <td>Not more than the specified value.</td> </tr> <tr> <td>Capacitance Change</td> <td>Within ±10% of initial value.</td> </tr> <tr> <td>tan δ</td> <td>Not more than the specified value.</td> </tr> <tr> <td>Appearance</td> <td>There shall be no leakage of electrolyte.</td> </tr> </table>	Leakage current	Not more than the specified value.	Capacitance Change	Within ±10% of initial value.	tan δ	Not more than the specified value.	Appearance	There shall be no leakage of electrolyte.
Leakage current	Not more than the specified value.									
Capacitance Change	Within ±10% of initial value.									
tan δ	Not more than the specified value.									
Appearance	There shall be no leakage of electrolyte.									
4.13	Damp heat test IEC-60384-4 4.12	<p><Condition> Humidity test: According to IEC60384-4 No.4.12 methods, capacitor shall be exposed for 500±8 hours in an atmosphere of 90~95%R H .at 40±2°C, the characteristic change shall meet the following requirement.</p> <p><Criteria></p> <table border="1" data-bbox="536 1626 1418 1798"> <tr> <td>Leakage current</td> <td>Not more than the specified value.</td> </tr> <tr> <td>Capacitance Change</td> <td>Within ±20% of initial value.</td> </tr> <tr> <td>tan δ</td> <td>Not more than 120% of the specified value.</td> </tr> <tr> <td>Appearance</td> <td>There shall be no leakage of electrolyte.</td> </tr> </table>	Leakage current	Not more than the specified value.	Capacitance Change	Within ±20% of initial value.	tan δ	Not more than 120% of the specified value.	Appearance	There shall be no leakage of electrolyte.
Leakage current	Not more than the specified value.									
Capacitance Change	Within ±20% of initial value.									
tan δ	Not more than 120% of the specified value.									
Appearance	There shall be no leakage of electrolyte.									

4.14

Change of
temperature
Test
IEC-60384-4 4.7

<Condition>

Temperature cycle:

According to IEC60384-4 No.4.7 methods, capacitor shall be placed in an oven, the condition according as below:

Temperature	Time
(1)+20℃	≤3 Minutes
(2) -40℃	30±2 Minutes
(3) +105℃	30±2 Minutes
(1) to (3)=1 cycle, total 5 cycle	

<Criteria>

The characteristic shall meet the following requirement.

Leakage current	Not more than the specified value.
tan δ	Not more than the specified value.
Appearance	There shall be no leakage of electrolyte.

4.15

Vent test
IEC-60384-4 4.16

<Condition>

The following test only apply to those products with vent products at diameter ≥Ø6.3 with vent.

D.C. test

The capacitor is connected with its polarity reversed to a DC power source. Then a current selected from Table 2 is applied.

<Table 2>

Diameter (mm)	DC Current (A)
22.4 or less	1

<Criteria>

The vent shall operate with no dangerous conditions such as flames or dispersion of pieces of the capacitor and/or case.

5. CASE SIZE & MAX RIPPLE CURRENT

Size Φ D x L(mm) , Maximum Allowable Ripple Current(mA) at 105°C,120 Hz

μ F	WV	4 (0G)		6.3(0J)		10(1A)		16(1C)	
	Item	D×L	Ripple Current	D×L	Ripple Current	D×L	Ripple Current	D×L	Ripple Current
10								4x5	18
22	4x5	22	4x5	22	4x5	24	4x5	4x5 5x5	22 30
33	5x5	30	5x5	30	5x5	35	5x5	6.3x5	40
47	5x5	36	5x5	36	6.3x5	46	6.3x5	5x5 6.3x5	50 60
100	6.3x5	60	6.3x5	60	6.3x5	67	6.3x5	6.3x5	73
220			8x5	103	8x5	116	8x5	8x5	126
330			8x5	127					

μ F	WV	25(1E)		35(1V)		50(1H)	
	Item	D×L	Ripple Current	D×L	Ripple Current	D×L	Ripple Current
2.2						4x5	14
3.3				4x5	11	4x5	14
4.7	4x5	13	4x5	15	4x5 5x5	17 19	
10	4x5 5x5	20 25	5x5	25	6.3x5	30	
22	6.3x5	38	6.3x5	48	8x5	52	
33	6.3x5	48	6.3x5	52	8x5	63	
47	6.3x5	58	8x5	82			
100	8x5	97					

Remark:

1)Specification are subject to change without notice should a safety or technical concern arise regarding the product ,please be sure to contact our sales offices;

2)The sizes in the above table are all general specifications; If you need other specifications, please contact us.

6. Dimensions:

Unit: mm

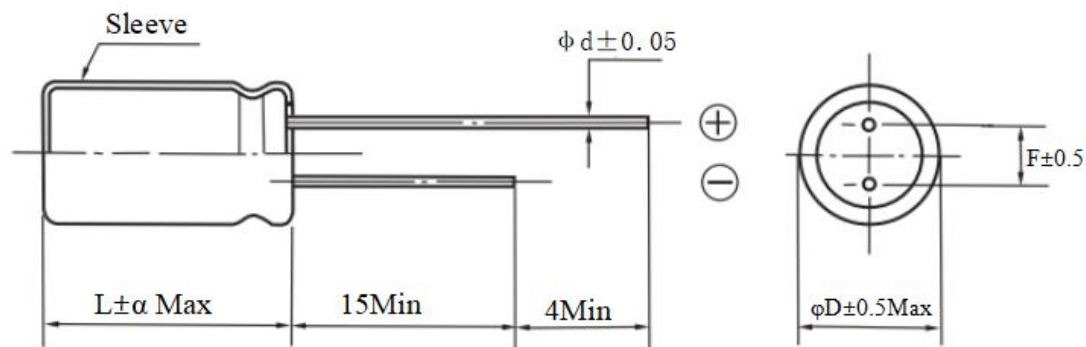

ϕD	4.0	5.0	6.3	8.0
F	1.5	2.0	2.5	2.5
ϕd	0.45			
α	1.0			

7. Multiplier for Ripple Current

Frequency coefficient

Coefficient	Frequency (Hz)				
	50	120	300	1K	$\geq 10K$
Cap(μF)					
$\leq 47 \mu F$	0.75	1.00	1.35	1.57	2.00
$\geq 68 \mu F$	0.80	1.00	1.23	1.34	1.50

Temperature coefficient

Ambient Temperature	105	85	≤ 70
Coefficient	1.0	1.5	2.0

8. Marking:

Unless otherwise specified. Capacitor shall be clearly marked on it body.

- (1) Brand: Aillen
- (2) Polarity: 
- (3) Nominal capacitance: 47 μ F
- (4) Rated voltage: 25V
- (5) Series: CD11ET
- (6) Temperature Range: -40~+105 $^{\circ}$ C

Casing Type:

47 μ F 25V	47 μ F 25V
	
Aillen CD11ET -40~+105 $^{\circ}$ C	Aillen CD11ET -40~+105 $^{\circ}$ C

Sleeve and printing color: White Printing on black Sleeve.

9. Forming Dimension

Cutting Type

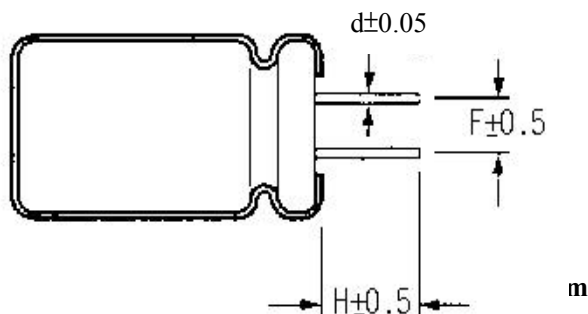

Shape Code	ϕD	$\Phi 4$	$\phi 5$	$\phi 6.3$	$\phi 8$
CB Cutting-3.5mm	F	1.5	2.0	2.5	3.5
	H	3.5	3.5	3.5	3.5
	d	0.45	0.45	0.45	0.45/0.50
Shape Code	ϕD	$\Phi 4$	$\phi 5$	$\phi 6.3$	$\phi 8$
CC Cutting-4.0mm	F	1.5	2.0	2.5	3.5
	H	4.0	4.0	4.0	4.0
	d	0.45	0.45	0.45	0.45/0.50
Shape Code	ϕD	$\Phi 4$	$\phi 5$	$\phi 6.3$	$\phi 8$
CD Cutting-4.5mm	F	1.5	2.0	2.5	3.5
	H	4.5	4.5	4.5	4.5
	d	0.45	0.45	0.45	0.45/0.50
Shape Code	ϕD	$\Phi 4$	$\phi 5$	$\phi 6.3$	$\phi 8$
CE Cutting-5.0mm	F	1.5	2.0	2.5	3.5
	H	5.0	5.0	5.0	5.0
	d	0.45	0.45	0.45	0.45/0.50

Issued-date: 2022-11-05

Name

Specification Sheet – CD11ET

Revision

B

Page

14

10. Taping Dimension:

10.1 Enlarge the foot braid:

Fig1

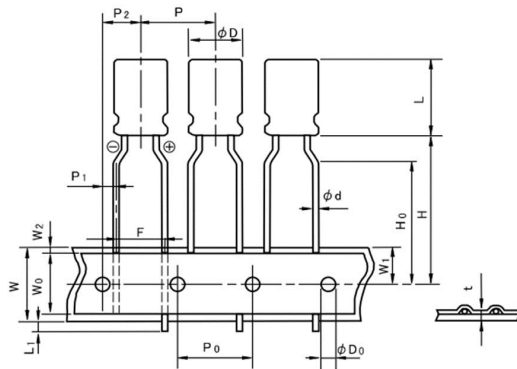
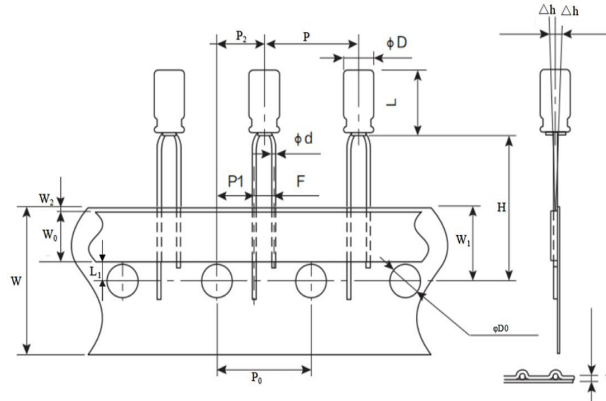

Fig2



Taping dimension

Unit: mm

Code		TB	T5	TB	T5	TB	T5	T5	T5	T5	T5	T5	T5
Item		Fig2	Fig1	Fig2	Fig1	Fig2	Fig1	Fig1	Fig1	Fig1	Fig1	Fig1	Fig1
Taping Code		Fig2	Fig1	Fig2	Fig1	Fig2	Fig1	Fig1	Fig1	Fig1	Fig1	Fig1	Fig1
Diameter	ϕD	4		5		6.3				8			
Height	L	5&7		5&7		9~12		5&7	9~12	5	7	9~19	20~25
Lead Diameter	$\phi d \pm 0.05$		0.45		0.50	0.45	0.50		0.45		0.50	0.60	
Component Spacing	$P \pm 1.0$									12.7			
Pitch of sprocket holes	$P_0 \pm 0.2$									12.7			
Distance between centers of terminal and the sprocket holes	$P_1 \pm 0.5$	5.1	3.85	5.1	3.85	5.1	3.85	3.85	3.85	3.85	4.6	4.6	4.6
Feed hole center to component center	$P_2 \pm 1.0$	6.35	6.35	6.35	6.35	6.35	6.35	6.35	6.35	6.35	6.35	6.35	6.35
Distance between centers of component leads	$F \pm 0.5$	2.5	5.0	2.5	5.0	3.5	5.0	5.0	5.0	5.0	5.0	5.0	5.0
Carrier tape width	$W \pm 1$									18			
Hold down tape width	W_0									7min			
Distance between the center of upper edge of carrier tape and sprocket hole	$W_1 \pm 0.5$									9			
Distance between the upper edges of the carrier tape and the hold down tape	W_2									3max			
Distance between the abscissa and the bottom of the components body	$H \pm 0.75$	18.5	17.5	18.5	17.5	18.5	17.5	17.5	17.5	20	20	20	20
Distance between the abscissa and the reference plane of he components with crimped leads	$H_0 \pm 0.5$	/	16.0	/	16.0	/	16.0	16.0	16.0	16.0	16.0	16.0	16.0
Max. lateral deviation of the component body vertical to the tape plane	Δh									2 max			
End of lead	L_1									0.5Max			
Dia. of driving hole	ϕD_0									4.0 \pm 0.2			
Sun of thickness for mounting and adhesive tape without lead dia	t									0.6 \pm 0.3			

Issued-date: 2022-11-05

Name

Specification Sheet – CD11ET

Revision

B

Page

15

10.2 Taping Dimension Straight foot braid:

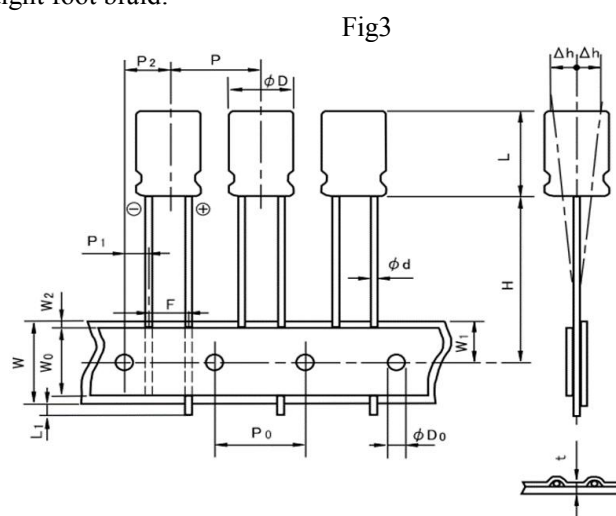

Taping dimension

Unit: mm

Code		T2	TB	T3
Item				
Taping Code		Fig1	Fig1	Fig1
Diameter	ϕD	5	6.3	8
Height	L	5~7		
Lead Diameter	$\phi d \pm 0.05$	0.45	0.45	0.45
Component Spacing	$P \pm 1.0$	12.7		
Pitch of sprocket holes	$P_0 \pm 0.2$	12.7		
Distance between centers of terminal and the sprocket holes	$P_1 \pm 0.5$	5.1	5.1	4.6
Feed hole center to component center	$P_2 \pm 1.0$	6.35	6.35	6.35
Distance between centers of component leads	$F \pm 0.5$	2.0	2.5	2.5
Carrier tape width	$W \pm 1$	18		
Hold down tape width	W_0	7min		
Distance between the center of upper edge of carrier tape and sprocket hole	$W_1 \pm 0.5$	9		
Distance between the upper edges of the carrier tape and the hold down tape	W_2	3max		
Distance between the abscissa and the bottom of the components body	$H \pm 1$	17.5	17.5	20.0
Distance between the abscissa and the reference plane of the components with crimped leads	$H_0 \pm 0.5$	/		
Max. lateral deviation of the component body vertical to the tape plane	Δh	2 max		
End of lead	L_1	0.5Max		
Dia. of driving hole	ϕD_0	4.0 \pm 0.2		
Sum of thickness for mounting and adhesive tape without lead dia	t	0.6 \pm 0.3		

Issued-date: 2022-11-05

Name

Specification Sheet – CD11ET

Revision

B

Page

16

STANDARD MANUAL

When using Aluminum Electrolytic Capacitors, please pay attention to the points listed below.

If the following types of electrical loads are applied to Aluminum Electrolytic Capacitors, rapid deterioration of electrical property occurs:

- Reverse voltage
- Over voltage exceeding rated working voltage
- Current exceeding rated ripple current
- Severe charging/discharging

At such times, severe heat is generated, gas is emitted, then electrolyte leaks from the sealed area, and pressure relief vent operates due to increase of internal pressure. In the worst case, explosion or ignition may occur, and along with destruction of the capacitor combustibles may burst out.

1. CAUTION DURING CIRCUIT DESIGN

1) OPERATIONAL ENVIRONMENT, MOUNTING ENVIRONMENT AND CONDITIONS

Ensure that operational and mounting conditions follow the specified conditions detailed in the catalog and specification sheets

2) OPERATING TEMPERATURE, RIPPLE CURRENT AND LOAD LIFE.

Operating temperature and applied ripple current should be within the specified value in the catalog or specification sheets.

Do not use Aluminum Electrolytic Capacitors at temperature which exceeds the specified category temperatures range.

Do not apply excessive current to the capacitors, which exceeds the specified rated ripple current.

During circuit design, please ensure that capacitors are selected to match with the lifetime requirements of the application

3) APPLICATION

Aluminum Electrolytic Capacitors are normally polarized. Reverse voltage or AC voltage should not be applied. When polarity may flip over, non-polar type should be used, but the non-polar type cannot be used for AC.

Standard Aluminum Electrolytic Capacitors are not suitable for rapid charge and discharge applications. Please consult with Shanghai Suzuki Electronics or sales office of Suzuki Techno Group in your area about special designed capacitors for rapid charge and discharge.

4) APPLIED VOLTAGE

Do not exceed the rated voltage of capacitors

5) INSULATION

Aluminum Electrolytic Capacitors should be electrically isolated from the following.

Aluminum case, cathode lead wire, anode lead wire and circuit pattern;

Auxiliary terminals of snap-in type, anode terminal, outward terminals and circuit pattern.

The PVC sleeve of Aluminum Electrolytic Capacitors is not recognized as an insulator, and therefore, the standard capacitor should not be used in a place where insulation function is needed.

Issued-date: 2022-11-05

Name

Specification Sheet – CD11ET

Revision

B

Page

17

Please consult with Shanghai Suzuki Electronics or sales office of Suzuki Techno Group in your area, if you require a higher grade of insulating sleeve.

6) CONDITIONS OF USE

The following environments should be avoided when using Aluminum Electrolytic Capacitors.

Damp conditions such as water, salt water or oil spray or fumes, high humidity or humidity condensation situations;

Hazardous gas/fumes such as hydrogen sulfide, sulfurous acid gas, nitrous acid, chlorine gas, ammonia or bromine gas;

Exposure of ozone, ultraviolet rays or radiation;

Severe vibration or shock which exceeds the condition specified in the catalog or specification sheets.

7) CONSIDERATION TO ASSEMBLY CONDITION

In designing a circuit, the following matters should be ensured in advance to the capacitor's assembly on the printed circuit board (PC board)

Design the appropriate hole spacing to match the lead pitch of capacitors;

Do not locate any wiring and circuit patterns directly above the capacitor's vent;

Ensure enough free space above the capacitor's vent. The recommended space is specified in the catalog or specification sheets;

In case the capacitor's vent is facing the PC board, make a gas release hole on PC board.

The sealing side of the screw terminal type should not face down in the application. When the capacitors are mounted horizontally, the anode screw terminals must be positioned at upper side.

8) CONSIDERATION TO CIRCUIT DESIGN

Any copper lines or circuit patterns should not be laid under the capacitor;

Parts which radiate heat should not be placed close to the reverse side of the Aluminum Electrolytic Capacitors on the PC board.

9) OTHERS

Performance of electrical characteristics of Aluminum Electrolytic Capacitors is affected by variation of operating temperature and frequency. Consider this variation when designing the circuit.

Excessive holes and connection hole between both sides on the PC board should be avoided around or under the mounting area of the Aluminum Electrolytic Capacitors on double sided or multilayer PC board.

Torque of tightening screw terminals should not exceed the specified maximum value which is described in the catalog and specification sheets.

Consider current balance when 2 or more Aluminum Electrolytic Capacitors are connected in parallel.

Use bleeder resistors when 2 or more Aluminum Electrolytic Capacitors are connected in series. In this case, the resistors should be connected parallel to the capacitors.

2. CAUTION FOR ASSEMBLING CAPACITORS

1) CAUTION BEFORE ASSEMBLY

Aluminum Electrolytic Capacitors cannot be recycled after mounting and applying electricity in unit. The capacitors, which are removed from PC board for the purpose of measuring electrical characteristics at the periodical inspection, should only be recycled for the same position.;

Aluminum Electrolytic Capacitors may accumulate charge naturally during storage. In this case, discharge through a 1KOHM resistor before use;

Leakage current of Aluminum Electrolytic Capacitors may be increased during long storage time. In this case, the capacitors should be subject to voltage treatment through a 1KOHM resistor before use.

2) IN THE ASSEMBLY PROCESS-1

Ensure rated voltage and capacitance of the capacitors before mounting;

Ensure capacitors polarity before mounting;

Do not use a capacitor which has been dropped onto a hard surface;

Do not use a capacitor with damaged or dented cases or seals.

3) IN THE ASSEMBLY PROCESS-2

Capacitors should be mounted after confirmation that hole spacing on PC board matches the lead pitch of the capacitors;

The snap-in type of capacitors should be mounted firmly on the PC board without a gap between the capacitor body and the surface of PC board.;

Avoid excessive force when clinching lead wire during auto-insertion process;

Avoid excessive shock to capacitors by automatic inserting machine, during mounting, parts inspection or centering operations;

Please utilize supporting material such as strap of adhesive to mount capacitors to PC board when it is anticipated that vibration or shock is applied.

4) SOLDERING

Soldering conditions (temperature, time) should be within the specified conditions which are described in the catalog or specification sheets;

In case lead wire reforming is needed due to inappropriate pitch between capacitor and holes on PC board, stress to the capacitor should be avoided;

In case of maintenance by soldering iron, if it is required to detach the capacitor, it should be removed from PC board after solder has melted sufficiently in order to reduce stress on the lead wires/terminals of the capacitor;

Soldering iron should never touch the capacitor's body.

5) FLOW SOLDERING

Do not dip capacitor's body into melted solder,.It should only be soldered on the reverse side of the PC board on which the capacitors are mounted;

Soldering condition((preheat,soldering temperature,dipping time)should be within the specified standard which is described in the catalog or specification sheets;

Flux should not be adhered to capacitor's body but only to its terminals;

Other devices which are mounted close to capacitors should not touch the capacitors.

6) REFLOW SOLDERING

Reflow soldering conditions(preheat,soldering,temperature,reflow time)should follow the specified standard which is described in the catalog or specification sheets;

Heating standard should depend on surface of the capacitor color or materials when infrared rays are used because the capacitor's heat absorption depends on the surface color or materials.Check heat condition;

Standard Aluminum Electrolytic Capacitors cannot withstand two or more reflow processes.

7) HANDLING AFTER SOLDERING

Do not bend or twist the capacitor's body after soldering on PC board;

Do not pick-up or move PC board by holding the soldered capacitors;

Do not hit the capacitors and isolate capacitors from the PC board or other device when stacking PC boards in store.

8) PC BOARD CLEANING

Standard Aluminum Electrolytic Capacitors should be free from halogenated solvents during PC board cleaning after soldering.

9) ADHESIVES AND COATING MATERIALS

Do not use halogenated adhesives and coating materials to fix Aluminum Electrolytic Capacitors;

Flux between the surface of the PC board and sealing of capacitors should be cleaned before using adhesives or coating materials;

Solvents should be dried up before using adhesives or coating materials;

Do not cover up all the sealing area of capacitors with adhesives or coating materials,make coverage only partial.

3. CAUTION DURING USE OF CAPACITORS IN SETS

- 3.1 Do not touch the terminals of capacitors;
- 3.2 Do not connect electrical terminals of the capacitors.Keep the capacitors free from conductive solution,such as acid,alkali and so on;
- 3.3 Ensure the operational environment of the equipment in which the capacitor has been built is within the specified condition mentioned in the catalog or specification sheets.

4. MAINTENANCE

- 4.1 Periodical inspection should be carried out for the capacitors,which are used with industrial equipment; Check the following points at the inspection.
- 4.2 Visual inspection to check pressure relief vent open or leakage of electrolyte;
- 4.3 Electrical characteristics:leakage current,capacitance,dissipation factor and the other points which are mentioned in the catalog or specification sheets.

5. EMERGENCY ACTION

- 5.1 If the pressure relief vent is open and some gas blows out from the capacitor,turn the main switch of the equipment off or pull out the plug from the power outlet immediately;
- 5.2 During pressure relief vent operation,extremely hot gas(over 100°C)may blow out from the vent area of the capacitors.So keep your face and skin away from capacitors during its operation.In case of eye contact,flush the open eye(s)with large amount of clean water immediately.In case of ingestion,gargle with water immediately,and do not swallow.Also do not touch elctrolyte but wash skin with soap and water in case of skin contact.

6. STORAGE CONDITIO

- 6.1 Aluminum Electrolytic Capacitors should not be stored in high temperature or in high humidity.The suitable storage condition is 5°C-35°C,and less than 75% in relative humidity;
- 6.2 Aluminum Electrolytic Capacitors should not be stored in damp conditions such as water,salt water spray or oil spray;
- 6.3 Do not store Aluminum Electrolytic Capacitors in an environment full of hazardous gas (hydrogen sulfide gas,sulfurous acid gas,nitrous acid,chlorine gas,ammonia or btomine gas);
- 6.4 Aluminum Electrolytic Capacitors should not be stored under exposure to ozone ,ultraviolet rays or radiation.
- 6.5 After one year, a capacitor should be reconditioned by applying rated voltage in series with a 1000Ω current limiting resistor for a time period of 30 minutes.

7. DISPOSAL

- 1)Please take either of the following actions in case of disposal.
Incinerarion (high temperature of more than 800°C)after crushing the capacitor's body;
- 2)Consignment to specialists of industrial waste.

Issued-date: 2022-11-05	Name	Specification Sheet – CD11ET		
Revision	B	Page	21	
STANDARD MANUAL				