

ALTERNATION HISTORY RECORDS 变更记录

Date 日期	Version 版本	Mark 标记	Page 页码	Description 描述	Drafter 制定者	Approver 审批者
2020-6-12	A	/		首次发行	/	常斯琴

1. Applicable Scope:

This standard specification is for use in consumer electronics, computers, telecommunications, control instruments...etc.

2. Part Number:

It is composed by Type, Rated Wattage, Nominal Resistance, Tolerance and Package/Terminal Form . e.g.

<u>RSNF</u>	1W	10R	J	T/B
Type	Rated Wattage	Nominal Resistance	Tolerance	Package/Terminal Form

2.1 Type :

Anti-Pulse Non-Inductive Resistors are called "RSNF" & "RSSF"(small size).

2.2 Rated Wattage:

Shown by "W", such as 1/4W, 1/2W, 1W, 2W, 3W.

2.3 Nominal Resistance:

Ω , $K\Omega$ are its unit, which be in accordance with JIS-C6409 article 6 (EIA RS-196A) series.

Letter "10R" indicates resistance value 10Ω .

2.4 Tolerance:

It is measured by Bridge-method at room temperature and expressed by a capital letter.

G = $\pm 2\%$, J = $\pm 5\%$.

2.5 Package/Terminal Form:

T/R = tape & reel ; T/B = tape in box; Nil = Bulk; MG form, F forms.

Letter "PA" indicates radial type lead taping.

Remark : RSNF & RSSF Series Resistors are RoHS Compliant.

3. Rated Power:

Rated power is the value of Max load wattage specified at the ambient temperature of 70°C , and shall meet the functions of electrical and mechanical performance. When the ambient temperature surpasses above mentioned temperature, the value declines as per following DERATING CURVE.

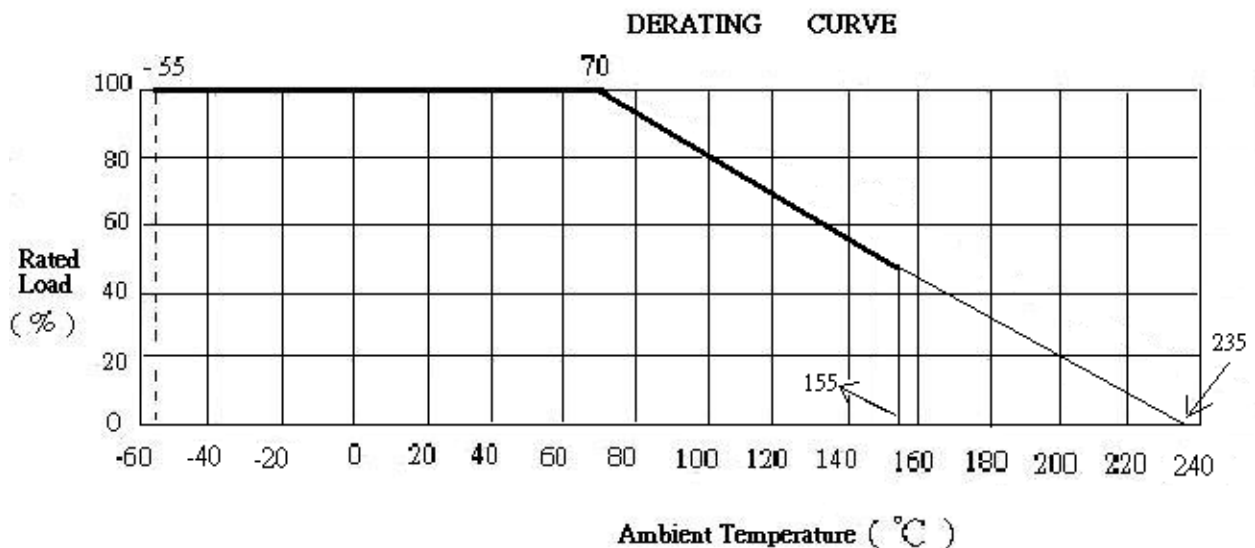

3.1 Rated Voltage:

It is calculated through the following formula:

$$E = \sqrt{P * R}$$

where E: rated voltage (V)

P: rated power (W)

R: nominal resistance value (Ω)

However, in case the voltage calculated exceeds the maximum load voltage, such the maximum load voltage shall be regarded as its rated voltage, means whichever less.

4. Dimension and structure:

4.1 Dimension:

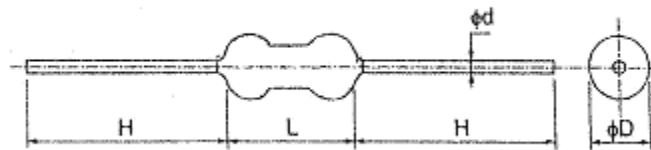

Unit: mm

TYPE		D±1	L±1	H±3	d±0.1	Resistance Range	Max Working Voltage	Max Overload Voltage
RSSF	RSNF							
1/2W	1/4W	2.6±0.5	6.8	28	0.6	0.22Ω ~200KΩ	250V	400V
	1/2W	3	9	28	0.65	0.22Ω ~200KΩ	300V	400V
1W		3.5	9	28	0.65	0.22Ω ~200KΩ	350V	600V
2W	1W	4.5	11	28	0.8	0.22Ω ~200KΩ	350V	600V
3W	2W	5	15	28	0.8	0.22Ω ~200KΩ	350V	600V

Notes: 1. Too low or too high ohmic values can be supplied only case by case.

2. Pricing is different, depending on resistance values.

4.2 STRUCTURE:

4.2.1 Ceramic Rod:

It is made of Forsterite imported from Japan.

4.2.2 Terminal:

Terminal is to be firmly connected with resistors element, both electrically and mechanically, and allow easy soldering.

4.2.3 Coating:

Coating is done by light gray flameproof paint for NRSN type and dark gray flameproof for NRSS (resistant to 800°C) which is solid enough to be free from looseness, crack and easy breakage. It is also resistant to cleaning and industrial solvents, and the paint shall be limited within 2mm of lead wires from resistor body.

4.2.4 Marking: Marking is made on resistors surface, by five color coding; 1st, 2nd, 3rd: nominal resistance, 4th: tolerance, 5th: white for Non-Inductive resistors.

5. Operating Temperature Range: -55°C ~ 155°C

6. Mechanical Performance:

6.1 Terminal tensile:

To fix the resistor body, a static load of 2.5kgs. (under 1/2W:1kg.) is to be gradually applied into the terminal for 10 seconds without causing any looseness and fall.

6.2 Twist withstand:

To bend the lead wire at the point of about 6mm from resistor body to 90°, then catch the wire at 1.2 ±0.4mm apart from the bent point end and turn it (clockwise) by 360 degrees perpendicular to the resistor axis at speed of 5 seconds per turn, and do the same counterclockwise again which constitute a whole turn. Repeat the turn 2 times without causing any break and looseness.

7. Electrical Performance:

7.1 Resistance Temperature Coefficient:

It shall be within ±300ppm/°C.

$$T.C \text{ (ppm/°C)} = \left[\frac{R2 - R1}{R1} \right] \times \left[\frac{1}{T2 - T1} \right] \times 10^6$$

where R1: resistance value at reference temperature
 R2: resistance value at test temp.
 T1: reference temp. (usu. 25°C)
 T2: test temp. (about 75°C)

7.2 Temperature Cycle:

Following temp. cycles are to be made 5 times and then put at room temp. for one hour, the resistance value change rate between pre-and-post test shall be within ±1%

Steps	Temperature(°C)	Time (minutes)
1 st step	-55 ± 3	30
2 nd step	Room temp.	3
3 rd step	155 ± 3	30
4 th step	Room temp.	3

7.3 Short Time Over Load:

When the resistors are applied 2.5 times as much as rated voltage for 5 seconds continuously, it shows no evidence of arc, flame...etc. Removing the voltage and place the resistors to the normal condition for 30 minutes, the resistance value change rate between pre-and-post test shall be within ±1% (RSSF=±2%).

7.4 Insulation Character :

Resistors are located in a V-shaped metal trough. Using the DC 100V megger instrument 2 poles to clutch either side of lead wires and metal trough, measuring the Insulation Resistance which shall be over 1000MΩ .

7.5 Voltage Withstanding:

Resistors are located in a V-shaped metal trough. Applying Max Working Voltage for one minute and should find no physical damage to the resistors, such as arc, char ...etc.

7.6 Load Life:

The resistors arrayed are sent into the 70°C oven, applying rated voltage at the cycle of 1.5 hours ON, 0.5 hour OFF for 1000₀⁺⁴⁸ hours in total. Then, after removing the voltage, take the resistors out of the oven and left under normal temp. for one hour cooling. The resistance value change rate between pre-and-post test shall be within ±5%.

7.7 Moisture-proof Load Life:

The resistors arrayed are placed into a constant temp./humidity oven at the temp. of 40 ±2°C and the humidity of 90~95%, then rated power is applied for 1.5 hours and cut off for 0.5 hour. The similar cycle will be repeated for 500₀⁺²⁴ hours in total (including cut-off time). Then remove the voltage, taking the resistors out of the oven and leaving them at room temp. for one hour. The resistance value change rate between pre-and-post test shall be within ±5%. There also shall be no evidence of remarkable change on appearance, and the marking shall not be illegible.

7.8 Solder-ability:

The leads with flux are dipped in a melted solder of 235 ±5°C for 2 seconds, more than 95% of the circumference of the lead wires shall be covered with solder.

7.9 Resistance to Soldering Heat:

Two leads are together dipped in a melted solder of 270 ±5°C for 10 ±1 seconds, or 350 ±10°C for 3.5 ±0.5 seconds, Then remove the resistors and leaving them at room temp. for one hour. The resistance value change rate between pre-and-post test shall be within ±1%.

7.10 Nonflammability:

The resistors are applied the power of 16 times the rated wattage for 5 min. and shall not get flame.

7.11 Inductance:

It shall be less than 1μ H.

8. Others:

8.1 MG Form:

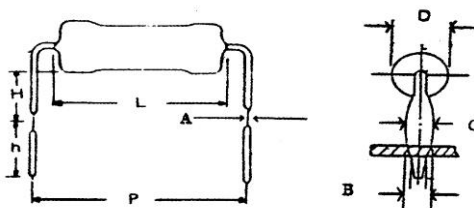

Unit: mm

RSSF	RSNF	D±1	L±1	P	H	h±1	A±0.02	B±0.05	C±0.2
1W		3.5	9	15±1.5	7±1	4.5	0.23	0.8	1.2
2W	1W	4.5	11	15±1.5	7±1	4.5	0.25	1	1.4
3W	2W	5	15	20±2	10±2	4.5	0.25	1	1.4

8.2 F Form:

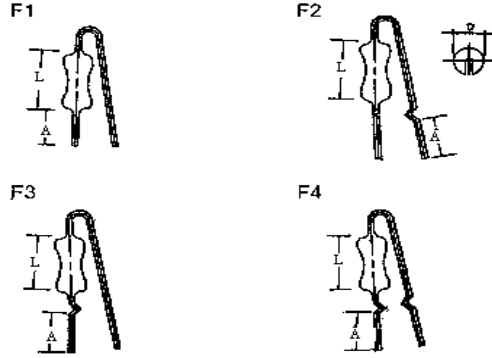

Unit: mm

RSSF	RSNF	D±1	L±1	A +1/-0.5	Applicable
1W		3.5	9	3.5	F1~F4
2W	1W	4.5	11	3.5	F1~F4
3W	2W	5	15	3.5	F1~F4

8.3 Packing:

8.3.1 Taping Specifications :

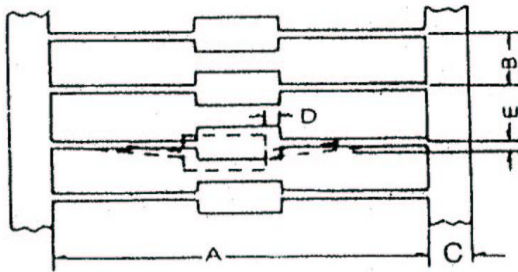

Unit: mm

RSSF	RSNF	Size		A	B	C ± 1	D Max	E Max
		Type						
≤1W	≤1/2W	T-52		52 ± 1	5 ± 0.5	6	0.6	1.2
2W	1W	T-63		63 ± 1	5 ± 0.5	6	0.6	1.2
3W	2W	T-63		63 ± 1	10 ± 1	6	0.6	1.2

8.3.2 Tape in Box:

Unit: mm

RSSF	RSNF	Type	QTY PER BOX	a	b	c
1/2W	1/4W	T-52	5,000	75	100	255
	1/2W	T-52	1,000	75	55	255
1W		T-52	1,000	75	55	255
2W	1W	T-63	1,000	85	105	260
3W	2W	T-63	1,000	100	110	265

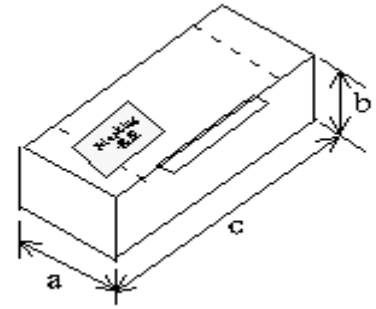

8.3.3 Tape & Reel:

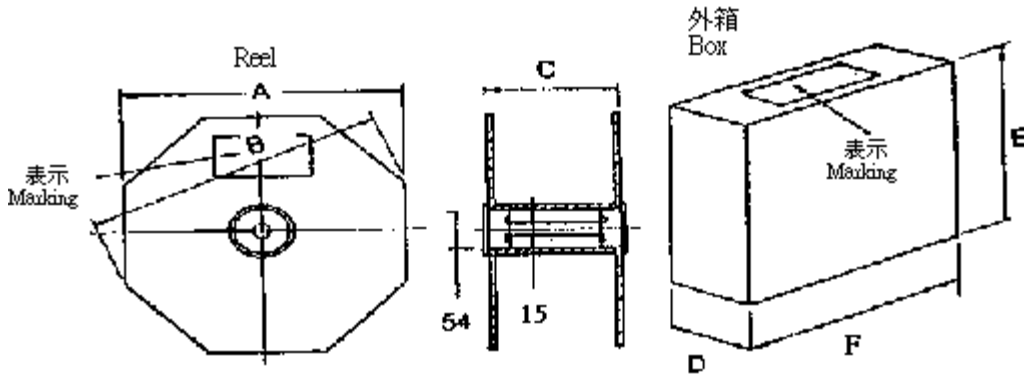

Unit: mm

RSSF	RSNF	Type	QTY PER REEL	A	B	C	D	E	F
1/2W	1/4W	T-52	5,000	285	310	75	80	295	295
	1/2W	T-52	5,000	305	330	75	90	310	310
1W		T-52	2,500	285	310	75	80	295	295
2W	1W	T-63	2,500	285	310	75	80	295	295
3W	2W	T-63	1,000	285	310	75	80	295	295

8.3.4 Radial type lead tapping(PA):

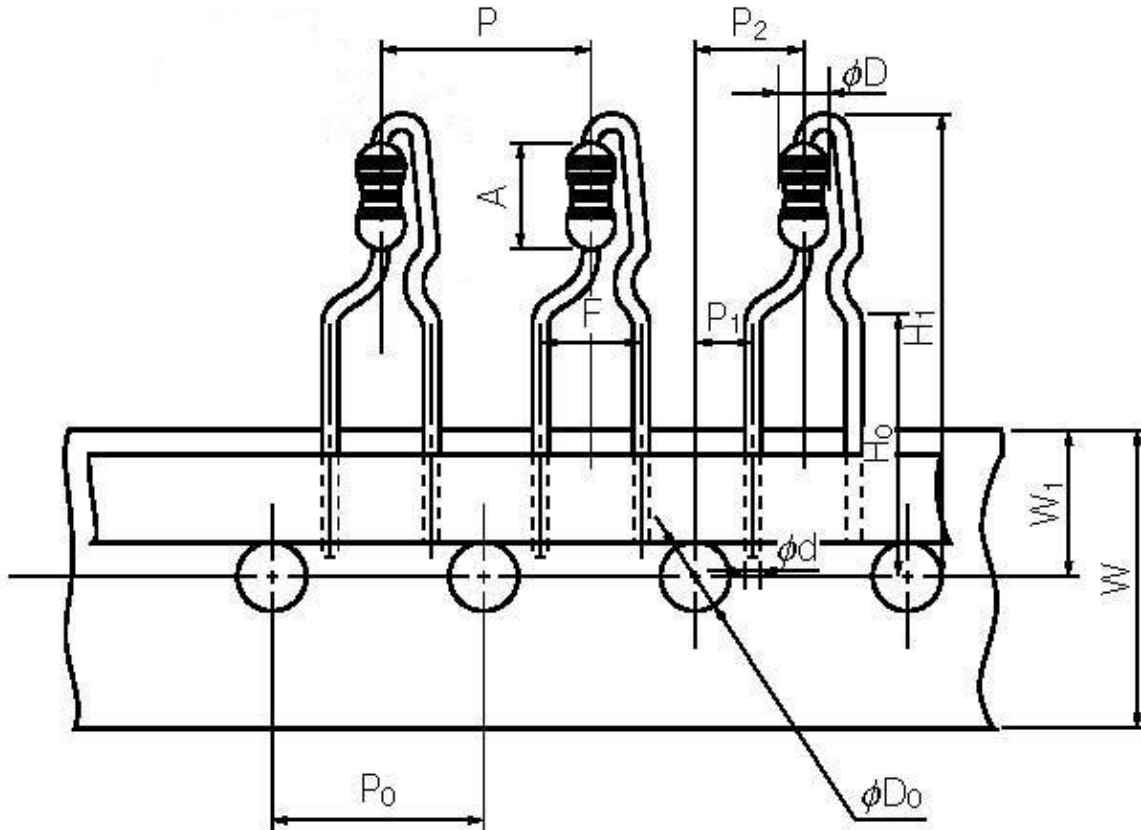

Unit: mm

RSSF	RSNF	P ±1	P ₀ ±0.3	P ₁ ±0.7	P ₂ ±1	F ±0.8	W ±0.5	W ₁ ±0.5	H ₁ max	H ₀ ±0.5	φ D ₀ ±0.2	A ±1	φ d ±0.1	φ D ±1
1/2W	1/4W	12.7	12.7	3.85	6.35	5	18	9	32	16	4	6.8	0.6	2.6±0.5
1W		12.7	12.7	3.85	6.35	5	18	9	32	16	4	9	0.65	3.5
2W	1W	12.7	12.7	3.85	6.35	5	18	9	38	16	4	11	0.8	4.5