

ALTERNATION HISTORY RECORDS 变更记录

Date 日期	Version 版本	Mark 标记	Page 页码	Description 描述	Drafter 制定者	Approver 审批者
2021-01-06	A	/	9	Initial release	Doris	/

1. Part Numbering System :

<u>ATP</u>	<u>12</u>	<u>J</u>	<u>A</u>	<u>10K</u>
Series Name Chip Resistor: ATP: Thick-film Power Automotive	TypeInch (mm) 03-0603(1608) 05-0805(2012) 06-1206(3216) 10-1210(3225) 0A-2010(5025) 12-2512(6432)	Tolerance F= ± 1.0% J= ± 5.0% P=Jumper	Package A=4Kpcs/7"Reel B=5Kpcs/7"Reel C=10Kpcs/7"Reel	Resistance 1R2=1.2 Ω 10K=10K Ω 10K5=10.5K Ω 100K=100K Ω 1M2=1.2M Ω

2. Features

- High power rating to 2W and compact size.
- High reliability and high precision (1%).
- Suitable for lead free soldering.
- Meet AEC-Q200, RoHS compliant & Halogen Free.

3. Applications

- Power supply.
- Automotive industry.
- Digital meter, Consumer electronics, M/B.
- LED Lighting.
- Industry control board.

4.Dimension and Construction

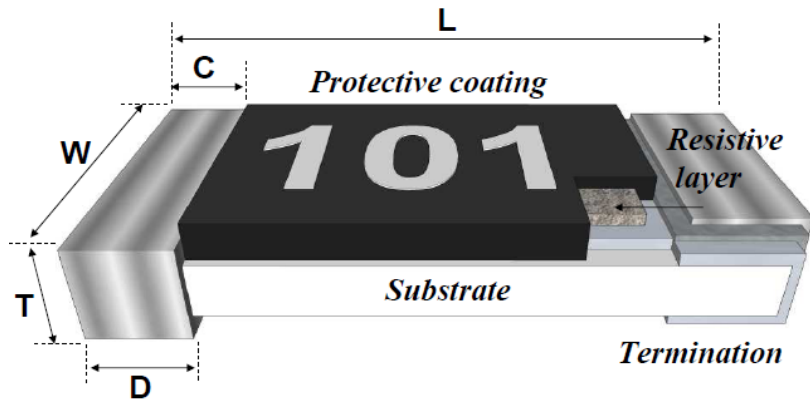

Unit : mm

Type	L	W	C	D	T
ATP03	1.60±0.10	0.80±0.10	0.30±0.20	0.30±0.20	0.45±0.10
ATP05	2.00±0.10	1.25±0.10	0.40±0.20	0.40±0.20	0.50±0.10
ATP06	3.10±0.10	1.60±0.10	0.50±0.25	0.50±0.25	0.55±0.10
ATP10	3.10±0.10	2.60±0.10	0.50±0.25	0.50±0.25	0.55±0.10
ATP0A	5.00±0.20	2.50±0.20	0.65±0.25	0.60±0.25	0.60±0.10
ATP12	6.40±0.20	3.10±0.20	0.60±0.25	1.80±0.25	0.60±0.15

5.Power Derating Curve

Operating Temperature Range: -55 to +155 deg.C

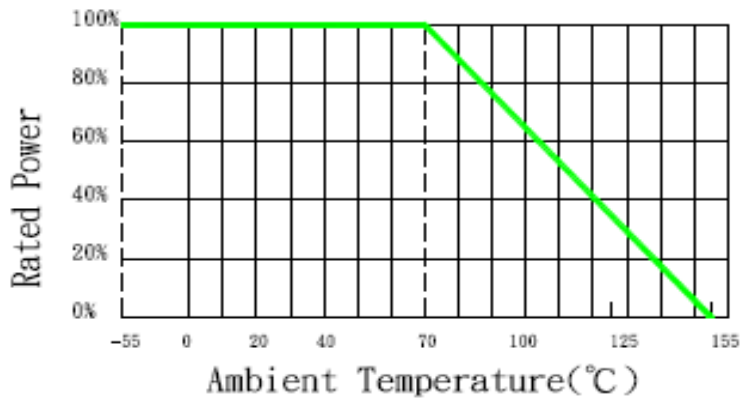

6.Rating

Type	Size	Power Rating at 70°C	Max. RCWV	Max. Overload Voltage	Resistance Tolerance	Resistance		Temperature Coefficient (ppm/°C)
						Min.	Max.	
ATP03	0603	1/8W	50V	100V	±1%(F) ±5%(J)	1Ω	1MΩ	TCR (ppm/°C) 20°C ~ +155°C ±100ppm
						10.2Ω	1MΩ	TCR (ppm/°C) 20°C ~ -55°C ±100ppm
						1Ω	10Ω	TCR (ppm/°C) 20°C ~ -55°C ±150ppm
ATP05	0805	1/4W	150V	300V	±1%(F) ±5%(J)	1Ω	1MΩ	TCR (ppm/°C) 20°C ~ +155°C ±100ppm
						10.2Ω	1MΩ	TCR (ppm/°C) 20°C ~ -55°C ±100ppm
						1Ω	10Ω	TCR (ppm/°C) 20°C ~ -55°C ±150ppm
ATP06	1206	1/2W	200V	400V	±1%(F) ±5%(J)	1Ω	1MΩ	±100ppm
ATP10	1210	1/2W	200V	400V	±1%(F) ±5%(J)	10.2Ω	1MΩ	TCR (ppm/°C) 20°C ~ +155°C ±100ppm
						1Ω	10Ω	TCR (ppm/°C) 20°C ~ +155°C ±200ppm
						10.2Ω	1MΩ	TCR (ppm/°C) 20°C ~ -55°C ±100ppm
						1Ω	10Ω	TCR (ppm/°C) 20°C ~ -55°C ±200ppm
ATP0A	2010	1W	200V	400V	±1%(F) ±5%(J)	1Ω	1MΩ	±100ppm
ATP12	2512	2W	300V	600V	±1%(F) ±5%(J)	1Ω	1MΩ	±100ppm

Note :

1. This is the maximum voltage that may be continuously supplied to the resistor element, see "IEC publication 60115-8"
2. Max. Operation Voltage : So called RCWV (Rated Continuous Working Voltage) is determined by

$$RCWV = \sqrt{\text{Rated Power} \times \text{Resistance Value}}$$
or Max. RCWV listed above, whichever is lower.

Test Conditions for Jumper: (0 Ω)

Item	ATP12		ATP10	ATP06	ATP05	ATP03
Power Rating At 70°C	2W	1W	1/2W	1/2W	1/4W	1/8W
Resistance	Max. 20mΩ					
Rated Current	10A	7A	5A	5A	3.5A	2.5A
Peak Current	25A	17.5A	12.5A	12.5A	8.8A	6.2A
Operating Temperature	-55 ~ +155°C					

7. Marking

Size \ Nr. Of digit of code\ tolerance	$\pm 5\%$	$\pm 1\%$
2512 (6432)	3-digits marking	4-digits marking
2010 (5025)	3-digits marking	4-digits marking
1210 (3225)	3-digits marking	4-digits marking
1206 (3216)	3-digits marking	4-digits marking
0805 (2012)	3-digits marking	4-digits marking
0603 (1608)	3-digits marking	3-digits marking

3-digits marking ($\pm 5\%$: 2512, 2010, 1210, 1206, 0805, 0603)

Each resistor is marked with a three digits code on the protective coating to designate the nominal resistance value.

3-digits marking ($\pm 1\%$: 0603)

Nominal resistance				Description											
1.E-24 series				As 0603 ATP03 $\pm 5\%$.											
2.E-96 series				The 1st two digit codes are referring to the CODE on the table, the 3rd code is the index of resistance value : $Y=10^{-2}$, $X=10^{-1}$, $A=10^0$, $B=10^1$, $C=10^2$, $D=10^3$, $E=10^4$, $F=10^5$ EX : 17.8 Ω =25X, 178 Ω =25A, 1K78 =25B 17K8=25C, 178K=25D, 1M78=25E											
3. Remark				There is no marking for the items are not under E-24 and E-96 series											
CODE	R_value	CODE	R_value	CODE	R_value	CODE	R_value	CODE	R_value	CODE	R_value	CODE	R_value	CODE	R_value
01	100	13	133	25	178	37	237	49	316	61	422	73	562	85	750
02	102	14	137	26	182	38	243	50	324	62	432	74	576	86	768
03	105	15	140	27	187	39	249	51	332	63	442	75	590	87	787
04	107	16	143	28	191	40	255	52	340	64	453	76	604	88	806
05	110	17	147	29	196	41	261	53	348	65	464	77	619	89	825
06	113	18	150	30	200	42	267	54	357	66	475	78	634	90	845
07	115	19	154	31	205	43	274	55	365	67	487	79	649	91	866
08	118	20	158	32	210	44	280	56	374	68	499	80	665	92	887
09	121	21	162	33	215	45	287	57	383	69	511	81	681	93	909
10	124	22	165	34	221	46	294	58	392	70	523	82	698	94	931
11	127	23	169	35	226	47	301	59	402	71	536	83	715	95	953
12	130	24	174	36	232	48	309	60	412	72	549	84	732	96	976

8.Soldering Reference :

The robust construction of chip resistors allows them to be completely immersed in a solder bath of 260°C for 10 seconds. Therefore, it is possible to mount Surface Mount Resistors on one side of a PCB and other discrete components on the reverse (mixed PCBs).

Surface Mount Resistors are tested for solderability at 235°C during 2 seconds. The test condition for no leaching is 260°C for 30 seconds. Typical examples of soldering processes that provide reliable joints without any damage are given in Fig 1.

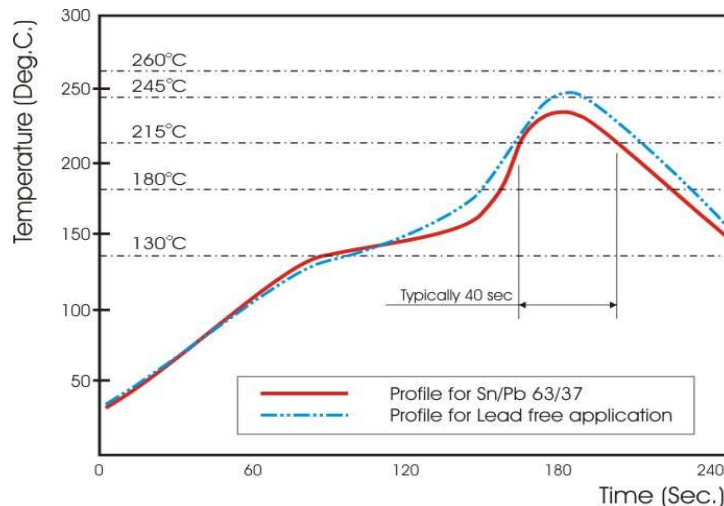
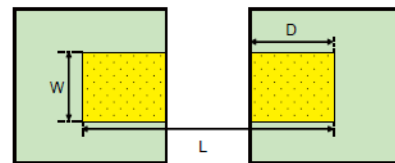

Fig 1. Infrared soldering profile for Chip Resistor

9.Recommend Solder Pad Dimensions :

Type	W	D	L
ATP03	0.90	1.00	3.00
ATP05	1.30	1.15	3.50
ATP06	1.80	1.30	4.70
ATP10	3.00	1.30	4.70
ATP0A	3.00	1.50	6.80
ATP12	3.70	2.45	7.60



Unit:mm

10.Test and Requirements :

Essentially all tests are carried out according to the schedule of IEC publication 115-8, category **LCT/UCT/56**(rated temperature range : **L**ower **C**ategory **T**emperature, **U**pper **C**ategory **T**emperature; damp heat, long term, 56 days). The testing also meets the requirements specified by EIA, EIAJ and JIS.

The tests are carried out in accordance with IEC publication 68, "Recommended basic climatic and mechanical robustness testing procedure for electronic components" and under standard atmospheric conditions according to IEC 60068-1, subclause 5.3. Unless otherwise specified, the following value supplied :

Temperature: 15°C to 35°C.

Relative humidity: 45% to 75%.

Air pressure: 86kPa to 106 kPa (860 mbar to 1060 mbar).

All soldering tests are performed with mildly activated flux.

Test Item	Specification	Test Method (AEC-Q200. IEC 60115)
*DC Resistance	F : $\pm 1\%$; J : $\pm 5\%$	AEC-Q200 TABLE 7.1 IEC 60115-1 / JIS C 5201-1 , Clause 4.5 Measure the resistance Value.
High Temperature Exposure (Storage)	J : $\Delta R \leq \pm(3\%+0.1\Omega)$ F : $\Delta R \leq \pm(1\%+0.05\Omega)$	AEC-Q200 TABLE 7.3 1000 hrs. @ T=125°C. Unpowered. Measurement at 24 ± 2 hours after test conclusion.
*Temperature Cycling	J : $\Delta R \leq \pm(1\% + 0.1\Omega)$ F : $\Delta R \leq \pm(0.5\% + 0.05\Omega)$ No mechanical damage.	AEC-Q200 TABLE 7.4 1000 Cycles (-55°C to +125°C). Measurement at 24 ± 2 hours after test conclusion.
Moisture Resistance	J : $\Delta R \leq \pm(1\%+0.1\Omega)$ F : $\Delta R \leq \pm(0.5\%+0.05\Omega)$	AEC-Q200 TABLE 7.6 Test 65°C/80~100%RH/10Cycles. Measurement at 24 ± 2 hours after test conclusion. (t=24hrs/cycle).
Biased Humidity	J : $\Delta R \leq \pm(3\%+0.1\Omega)$ F : $\Delta R \leq \pm(1\%+0.05\Omega)$	AEC-Q200 TABLE 7.7 1000 hours 85°C/85%RH. 10% of operating power. Measurement at 24 ± 2 hours after test conclusion.
Operational Life	J : $\Delta R \leq \pm(3\%+0.1\Omega)$ F : $\Delta R \leq \pm(1\%+0.05\Omega)$	AEC-Q200 TABLE 7.8 Test 1000hr @ TA=125°C at specified rated power. Measurement at 24 ± 2 hours after test conclusion.
External Visual	No visual damage and refer PDC marking code.	AEC-Q200 TABLE 7.9 Inspect device construction, marking and workmanship.
Physical Dimension	Within the spec.	AEC-Q200 TABLE 7.10 Verify physical dimensions to the applicable device detail specification.
Mechanical Shock	Within product specification tolerance and no visible damage.	AEC-Q200 TABLE 7.13 Test Peak value:100g's,Wave:Hail-sine, Duration:6ms,Velocity:12.3ft/sec.
Vibration	No mechanical damage.	AEC-Q200 TABLE 7.14 5 g's for 20 min., 12 cycles each of 3 orientations. Test from 10-2000 Hz.

*Resistance to Solder Heat	J : $\Delta R \leq \pm(1\% + 0.1\Omega)$ F : $\Delta R \leq \pm(0.5\% + 0.05\Omega)$ No mechanical damage.	AEC-Q200 TABLE 7.15 Solder dipping @ 270°C ±5°C for 10sec.±1sec.
Thermal Shock	J : $\Delta R \leq \pm(1\% + 0.1\Omega)$ F : $\Delta R \leq \pm(0.5\% + 0.05\Omega)$ No mechanical damage.	AEC-Q200 TABLE 7.16 -55 to 155°C / dwell time 15min/ Max transfer time 20sec/ 300cycles.
ESD	$\Delta R \leq \pm(1\% + 0.1\Omega)$ No mechanical damage.	AEC-Q200-002 Test contact min. 1KV.
*Solder Ability	Over 95% of termination must be covered with solder.	AEC-Q200 TABLE 7.18 a) Baking 155°C 4H, dipping 235°C 5s b) Steam 1H, dipping 215°C 5s c) Steam 1H, dipping 260°C 7s
Flammability	Refer UL-94.	AEC-Q200 TABLE 7.20 UL-94 V-0 or V-1 are acceptable
*Board Flex	J : $\Delta R \leq \pm(1\% + 0.1\Omega)$ F : $\Delta R \leq \pm(0.5\% + 0.05\Omega)$ No mechanical damage.	AEC-Q200 TABLE 7.21 Bending 2mm 2512.2010.1210.1206, 3mm 0805.0603.
Terminal Strength	No mechanical damage	AEC-Q200 TABLE 7.22 Force 1 Kg for 60 seconds.
*Short Time Overload	J : $\Delta R \leq \pm(2\% + 0.1\Omega)$ F : $\Delta R \leq \pm(1\% + 0.05\Omega)$	IEC 60115-1, Clause 4.13 5 × Rated power for 5 seconds
*Load Life Humidity	J : $\Delta R \leq \pm(3\% + 0.1\Omega)$ F : $\Delta R \leq \pm(1\% + 0.05\Omega)$	IEC 60115-1, Clause 4.24 40±2°C with relative humidity 90% ~ 95% D.C. rated voltage for 1.5 hours ON 30 minutes OFF. Cycle repeated 1000 hours.
*Temperature Coefficient of Resistance (TCR)	Within the spec.	IEC 60115-1, Clause 4.8 $T_1 \quad T_2$ Test temperature : 25°C ~ -55°C 25°C ~ +155°C $TCR(ppm/^\circ C) = (R_2 - R_1) / R_1 \times 1 / (T_2 - T_1) \times 10^6$
*Load Life	J : $\Delta R \leq \pm(3\% + 0.1\Omega)$ F : $\Delta R \leq \pm(1\% + 0.05\Omega)$	IEC 60115-1, Clause 4.25 Rated voltage for 1.5 hours for followed by a pause 0.5 hour at 70±2°C. Cycle repeated 1000 hours.
*Insulation Resistance	Between termination and coating must over 1000MΩ	IEC 60115-1, Clause 4.6 Test voltage : 100±15V

* Normal test items for standard product.

11. Packaging:

11.1 Peel Strength of Top Cover Tape

The peel speed shall be about 300 mm/min

The peel force of top cover tape shall be between 0.1 to 0.7N

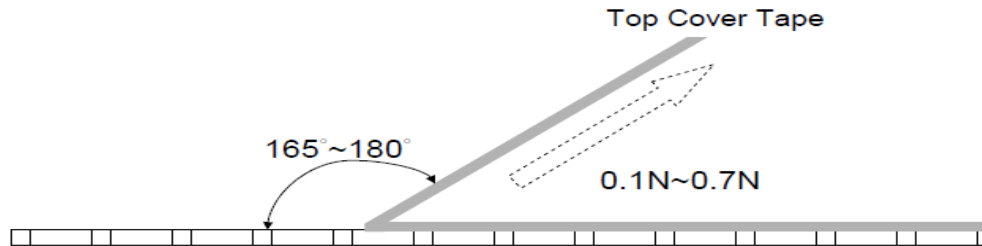

11.2 Paper Tape specifications (unit :mm)

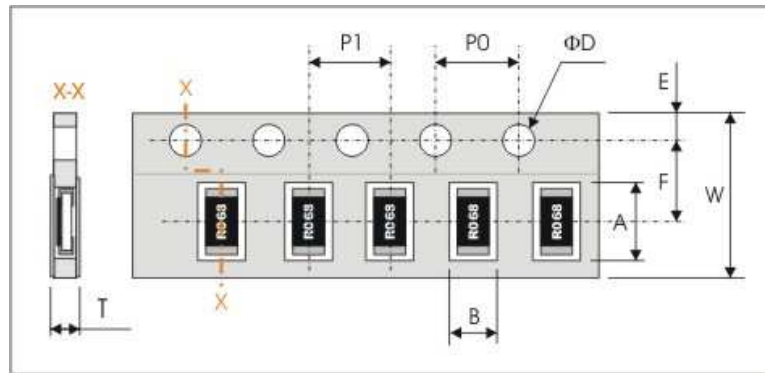

Series No.	A	B	W	F	E
ATP25	6.90±0.20	3.20±0.20	12.00±0.30	5.50±0.10	1.75±0.10
ATP0A	5.50±0.20	2.80±0.20	12.00±0.30	5.50±0.10	1.75±0.10
ATP10	3.60±0.20	3.00±0.20	8.00±0.30	3.50±0.20	1.75±0.10
ATP06	3.60±0.20	2.00±0.20			
ATP05	2.40±0.20	1.65±0.20			
ATP03	1.90±0.20	1.10±0.20			

Series No.	P1	P0	ΦD	T
ATP25	4.00±0.10	4.00±0.10	Φ1.50 ^{+0.1} _{-0.0}	Max. 1.2
ATP0A				Max. 1.2
ATP10				Max. 1.0
ATP06				Max. 1.0
ATP05				Max. 1.0
ATP03				0.65±0.05

11.3 Reel dimensions

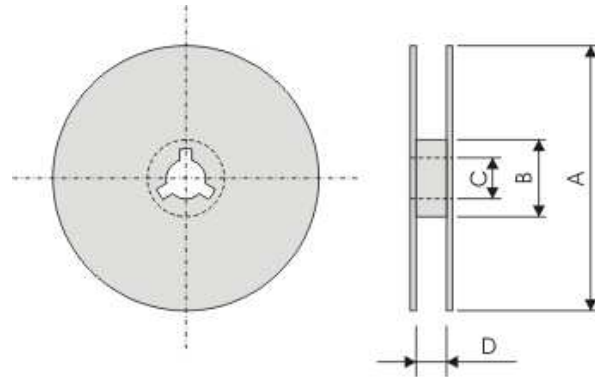

Symbol	A	B	C	D
12 mm tape	$\Phi 178.0 \pm 2.0$	$\Phi 60.0 \pm 1.0$	13.0 ± 0.2	12.4 ± 1.0
8 mm tape	$\Phi 178.0 \pm 2.0$	$\Phi 60.0 \pm 1.0$	13.0 ± 0.2	9.0 ± 0.5

12. Storage & Handling

... Products are recommended to be used up within one year as ensured shelf life.

Check solder ability in case shelf life extension is needed.

... To store products with following condition:

Temperature: 5 to 40°C ; Humidity: 20 to 70% relative humidity.

Precaution for use

The AEC-Q200 series resistors is mainly used on general automotive equipment without safety considerations.

Please contact our company in advanced if you intend to use resistor for designing the equipment which may damage itself and the safety of third party. If necessary, please consider to add the protect circuit in devising process and obtaining fully safety evaluation.