

## ALTERNATION HISTORY RECORDS 变更记录

Date 日期	Version 版本	Mark 标记	Page 页码	Description 描述	Drafter 制定者	Approver 审批者
2019-4-22	A	/	5	首次发行	常斯琴	彭旭

# POWER WIRE WOUND CHIP RESISTORS

---

## 1. Applicable Scope:

This standard specification is for use in consumer electronics, computers, telecommunications, control instruments...etc.

## 2. Part Number:

It is composed by Type, Rated Wattage, Nominal Resistance and Tolerance. e.g.

SMW    2W    10R    J  
Type    Rated Wattage    Nominal Resistance    Tolerance

### 2.1 Type :

Power Wire Wound Chip Resistors are called "SMW".

### 2.2 Rated Wattage:

Shown by "W", such as 2W, 3W, 5W.

### 2.3 Nominal Resistance:

$\Omega$ ,  $K\Omega$  are its unit, which be in accordance with JIS-C6409 article 6 (EIA RS-196A) series.

Letter "10R" indicates resistance value  $10\Omega$ .

### 2.4 Tolerance:

It is measured by Bridge-method at room temperature and expressed by a capital letter.

J= $\pm 5\%$ , F= $\pm 1\%$ .

Remark :SMW Series Resistors are RoHS & Halogen Free Compliant.

## 3. Rated Power:

Rated power is the value of Max load power specified at the ambient temperature of  $20^{\circ}\text{C}$ , and shall meet the functions of electrical and mechanical performance. When the ambient temperature surpasses above mentioned temperature, the value declines as per following DERATING CURVE.

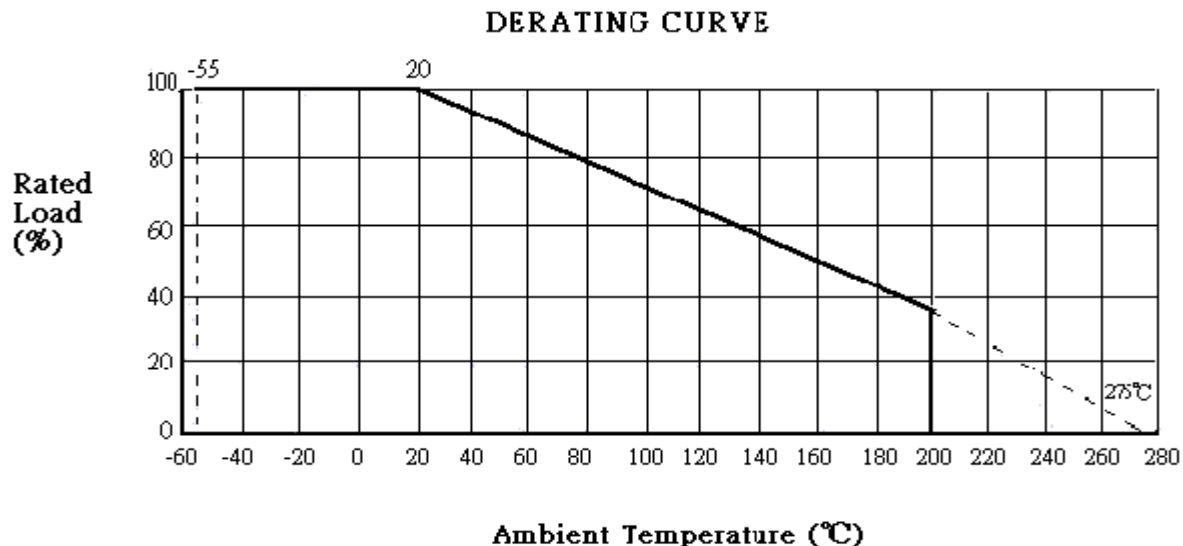

# POWER WIRE WOUND CHIP RESISTORS

## 3.1 Rated Voltage:

It is calculated through the following formula:

$$E = \sqrt{PXR}$$

where E: rated voltage (V)  
P: rated power (W)  
R: total nominal resistance ( $\Omega$ )

## 4. Dimension and structure:

### 4.1 Dimension:

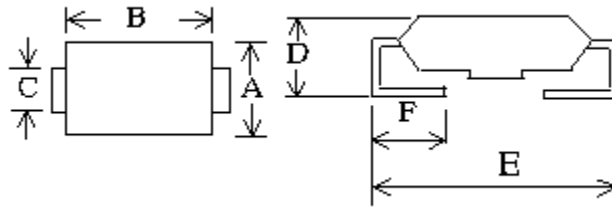

TYPE	Dimension (mm)						Resistance Range
	A $\pm$ 0.3	B $\pm$ 0.3	C $\pm$ 0.3	D $\pm$ 0.3	E max.	F $\pm$ 0.3	
2W	4.0	6.7	1.4	3.55	7.9	1.5	0.1 $\Omega$ ~200 $\Omega$
3W	5.5	10.5	1.7	5.0	12	2.3	0.1 $\Omega$ ~300 $\Omega$
5W	7.3	13.5	1.7	6.8	17	2.5	0.1 $\Omega$ ~680 $\Omega$

Note: Too low or too high ohmic values can be supplied only case by case.

### 4.2 Structure:

#### 4.2.1 Terminal:

Terminal is to be firmly connected with resistors element, both electrically and mechanically, and allow easy soldering.

#### 4.2.2 Coating:

Flameproof UL94V0 molded package, resistant to heat, humidity & insulation.

#### 4.2.3 Marking:

Marking is made on the surface with Rated Wattage, Nominal Resistance and Tolerance.

## 5. Operating Temperature Range: -55 $^{\circ}$ C ~ 200 $^{\circ}$ C

## 6. Electrical Performance:

### 6.1 Resistance Temperature Coefficient:

It shall be within :  $\pm 200$ ppm/ $^{\circ}$ C

$$T.C \text{ (ppm}/^{\circ}\text{C)} = \left[ \frac{R_2 - R_1}{R_1} \right] \times \left[ \frac{1}{T_2 - T_1} \right] \times 10^6$$

where R1: resistance value at reference temperature

R2: resistance value at test temp.

T1: reference temp. (usu. 25 $^{\circ}$ C)

T2: test temp. (about 75 $^{\circ}$ C)

### 6.2 Rated Load:

When the resistors are applied rated voltage for 30 minutes continuously, it shows no evidence of arc, flame...etc. Removing the voltage and place the resistors to the normal condition for 30 minutes, the resistance value change rate between pre-and-post test shall be within  $\pm 1\%$ .

# POWER WIRE WOUND CHIP RESISTORS

---

## 6.3 Temperature Cycle:

Following temp. cycles are to be made 5 times and then put at room temp. for one hour, the resistance value change rate between pre-and-post test shall be within  $\pm 1\%$ .

Steps	Temperature(°C)	Time (minutes)
1 <sup>st</sup> step	-55 $\pm$ 3	30
2 <sup>nd</sup> step	Room temp.	2~3
3 <sup>rd</sup> step	200 $\pm$ 3	30
4 <sup>th</sup> step	Room temp.	2~3

## 6.4 Short Time Over Load:

When the resistors are applied 5 times as much as rated wattage for 5 seconds continuously, it shows no evidence of arc, flame...etc. Removing the voltage and place the resistors to the normal condition for 30 minutes, the resistance value change rate between pre-and-post test shall be within  $\pm 1\%$ .

## 6.5 Voltage Withstanding:

Resistors are located in a jig and applying AC 500V for 1 minute and should find no physical damage to the resistors, such as arc, char...etc.

## 6.6 Insulation Character :

Resistors are located in a jig and applying DC 500V, measuring the Insulation Resistance which shall be over 10000M $\Omega$ .

## 6.7 Moisture-proof Load Life:

The resistors arrayed are placed into a constant temp./humidity oven at the temp. of 40 $\pm 2^\circ\text{C}$  and the humidity of 90~95%, then rated power is applied for 1.5 hours and cut off for 0.5 hour. The similar cycle will be repeated for 500 $_{0}^{+24}$  hours in total (including cut-off time). Then remove the voltage, taking the resistors out of the oven and leaving them at room temp. for one hour. The resistance value change rate between pre-and-post test shall be within  $\pm 2\%$ . There also shall be no evidence of remarkable change on appearance, and the marking shall not be illegible.

## 6.8 Load Life:

The resistors arrayed are sent into the 70 $^\circ\text{C}$  oven, applying rated voltage at the cycle of 1.5 hours ON, 0.5 hour OFF for 1000 $_{0}^{+48}$  hours in total. Then, after removing the voltage, take the resistors out of the oven and left under normal temp. for about one hour for cooling. The resistance value change rate between pre-and-post test shall be within  $\pm 2\%$ .

## 6.9 Solder-ability:

Immerse the resistors in the solder pot at 235  $\pm 5^\circ\text{C}$  for 2 seconds. At least 95% solder coverage on the termination.

## 6.10 Resistance to Soldering Heat:

Immerse the resistors in the solder pot at 270  $\pm 5^\circ\text{C}$  for 10  $\pm 1$  seconds. Then remove the resistors out of the solder pot and leaving them at room temp. for one hour for cooling. The resistance value change rate between pre-and-post test shall be within  $\pm 1\%$ .

# POWER WIRE WOUND CHIP RESISTORS

## 7. Tape & Reel:

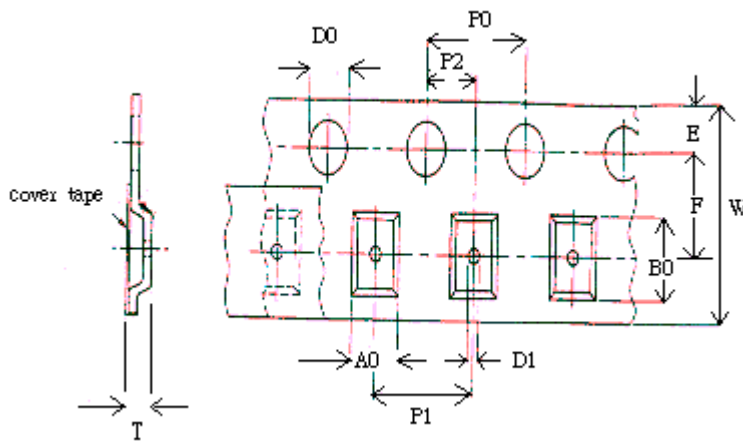
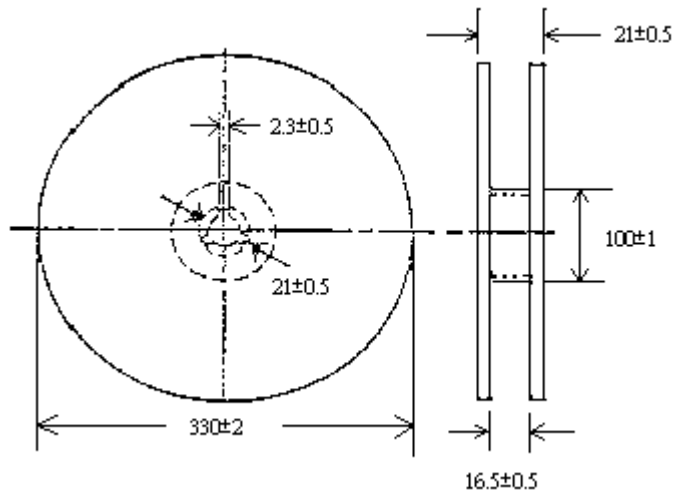

Unit:mm

Code	Rated Power	$B0 \pm 0.2$	$A0 \pm 0.2$	$P1 \pm 0.1$	$P2 \pm 0.1$	$P0 \pm 0.1$	$D0 \pm 0.1$	$E \pm 0.1$	$F \pm 0.1$	$W \pm 0.3$	$D1 \pm 0.1$	$T \pm 0.1$	pcs/reel
SMW	2W	8	4.3	8	2	4	1.5	1.75	7.5	16	1.5	4.15	2000
SMW	3W	11.8	5.8	12	2	4	1.5	1.75	11.5	24	1.5	5.8	1000
SMW	5W	17.5	7.8	16	2	4	1.5	1.75	14.2	32	1.5	7.5	500